



Title	The fate of intestinal parasites and pathogenic bacteria in the composting toilet
Author(s)	SOSSOU, Seyram Kossi
Citation	北海道大学. 博士(工学) 乙第6993号
Issue Date	2016-03-24
DOI	10.14943/doctoral.r6993
Doc URL	<a href="http://hdl.handle.net/2115/61934">http://hdl.handle.net/2115/61934</a>
Type	theses (doctoral)
File Information	Seyram_Kossi_SOSSOU.pdf



[Instructions for use](#)

# **The fate of intestinal parasites and pathogenic bacteria in the composting toilet**

*Submitted by*

**Seyram Kossi SOSSOU**

**A thesis submitted in partial fulfillment of the requirements for the degree of  
Doctor of Philosophy in Engineering**

**Examination Committee: Professor Naoyuki FUNAMIZU<sup>1</sup>  
Professor Masahiro Takahashi<sup>1</sup>  
Professor Taro Yamauchi<sup>2</sup>**

<sup>1</sup>Faculty of Engineering, Hokkaido University;

<sup>2</sup>Faculty of Health Science, Hokkaido University

**Laboratory on Engineering for Sustainable Sanitation, Division of Built  
Environment, Graduate School of Engineering,  
Hokkaido University, JAPAN**

**January 2016**

## ABSTRACT

On-site sanitation systems have gained much interest in recent years. One such system is the urine diverting composting toilet, which are promoted to sanitize human excreta for recycling them into fertilizer. A composting toilet using waste material as bulking agent has the potential to trap pathogens that might be contained in human feces. Unfortunately, in some marginal area, composting toilet could not get specific conditions for destroy all pathogens. Several studies have reported the inactivation of pathogenic bacteria and viruses in composting toilet. However, the removal of intestinal parasites has not been so far studied since parasites tend to have stronger resistance than pathogenic bacteria and viruses. Therefore, this study aimed to investigate the fate of intestinal parasites and pathogenic bacteria in the composting toilet for sanitizing compost from composting toilet.

**Chapter 1** describes the background and the objectives of this research. The literature review has summarized the state of the art regarding to the removal of pathogens in composting toilet, the inactivation mechanisms of the pathogen organism cells during the composting process and the different adequate post-treatments for sanitizing compost.

**Chapter 2** deals with the removal of intestinal parasites (helminthes eggs and protozoan cysts) and that of pathogenic bacteria during the composting process in a composting toilet. Batch experiments were conducted by composting human feces in an aerobic composting reactor during 60 days. The results showed that among parasites, protozoan cysts (*Entamoeba histolytica*) were present in humans feces collected at high concentration (854/g mean) than helminthes eggs (*Ascaris lumbricoides*) (204/g mean). A mesophilic temperature, desiccation and alkaline pH were obtained during the composting process. Compared to pathogenic bacteria (*Salmonella sp*), which were eliminated totally after 30 composting days, helminthes eggs were reduced after 35 days; while protozoan cysts were still present after 60 days. In high concentration, protozoan cysts have survived stronger than helminthes eggs in the composting toilet and may constitute a sanitary risk when used as fertilizer. Because of the persistence of intestinal parasites in composting toilet, both helminthes eggs and protozoan cysts are good indicator for the removal of intestinal parasites.

**Chapter 3** elucidates the inactivation mechanisms of pathogenic bacteria cells in composting toilet during the composting process. The inactivation mechanisms were evaluated by culture *E. coli* strain as pathogenic bacteria in 3 types of media namely Tryptic Soy Agar, Desoxycholate Agar and Compact Dry EC. By comparing, the inactivation rate constant of *E. coli*, the damaged components and/or functions of bacteria cell were estimated in three different composting matrixes (sawdust, rice husk and charcoal). The results showed that composting process and composting matrixes did not significantly affect inactivation rate of pathogenic bacteria; however, these differences affected damaging component or function of the bacteria cells. The composting process damaged the bacteria cell from membrane and enzyme to metabolisms while the composting matrix damaged from membrane to enzymes and metabolisms. However, the composting process, when accompanied with alkaline pH, changed the damage part of bacteria more lethally with nucleic acid damage.

**Chapter 4** evaluates the post-treatment of compost by storage treatment for a short time. Fresh composts produced in composting toilet with continuous feces supply, were stored for 2 months, in uncontrolled conditions. The microbiology analysis of fresh and stored composts, showed that, both composts contained indicator bacteria (fecal coliforms, enterococci, spores of sulphite-reducing clostridia), pathogenic bacteria (*Salmonella*) and intestinal parasites (helminthes eggs and protozoan cysts), at levels above suggested limits for compost quality. There was no significant difference of the microbial level in fresh and stored composts examined, thus the storage period tested resulted in slow reduction of microorganisms for compost quick sanitizing. However the microbial level in fresh and stored composts from a composting toilet was known and their health implications suggested further sanitizing treatments.

**Chapter 5** evaluates the post-treatment of compost by solar heating as thermal treatment. Fresh composts from composting toilet were inoculated with indicator microorganisms and subjected to solar heating (direct sunlight and solar box). The inactivation rate constant and the decimal decay of microorganisms in compost were estimated by using the inactivation kinetics. The result showed that the temperature regime produced by direct sunlight and solar box were categorized in mesophilic ( $>30^{\circ}\text{C}$ ) and pasteurization ( $>70^{\circ}\text{C}$ ), respectively. The log reduction of microorganisms in compost by solar box was significantly higher than that of direct sunlight. The inactivation of microorganisms was slower in compost heated by direct sunlight but fast in compost heated by solar box, thus the decimal decay occurred rapidly with solar box heating while it was prolonged with direct sunlight heating. The high and uniform temperature distribution obtained with solar box during heating proved to be an efficient option for sanitizing compost.

**Chapter 6** evaluates the post-treatment of compost by urea addition as alkaline treatment. Fresh composts from composting toilet were inoculated with indicator microorganisms and subjected to different urea concentrations (0.5-2% w/w) and temperatures (22, 32 and  $42^{\circ}\text{C}$ ). The inactivation kinetics parameters were determined in relation to pH, ammonia content and temperature during treatment time. The results showed that urea addition to compost enhanced inactivation of microorganisms. The inactivation rate constants of all microorganisms tested were positively correlated to the increase of  $\text{NH}_3$  (aq) concentration and temperature. The relationship between inactivation rate of microorganisms and ammonia through urea concentration and temperature were established. Therefore, the best decimal decay of *E. coli*, *enterococci* and *A.* eggs occurred with 2% w/w urea concentration at  $42^{\circ}\text{C}$  within 0.9, 1.1 and 1.4 days, respectively. Urea treatment has proved to be an efficient option for safe use of compost from composting toilet.

**Chapter 7** summarizes the most important findings as conclusions of this research and future studies are listed.

## LIST OF PUBLICATIONS

### I. Dissertation submitted for the degree

Title: The fate of intestinal parasites and pathogenic bacteria in the composting toilet

(コンポストトイレにおける腸管寄生虫と病原微生物の挙動)

### II. Published papers

1. **Sossou S. K.**, Sou/Dakoure M., Hijikata N., Quenum A., Maiga A. H. and Funamizu N. (2014) Removal and deactivation of intestinal parasites in aerobic mesophilic composting reactor for urine diverting composting toilet. *Compost Science and Utilization*, 22: 242-252. [doi.org/10.1080/09593330.2013.841268](https://doi.org/10.1080/09593330.2013.841268)
2. **Sossou S. K.**, Hijikata N., Sou M., Tezuka R., Maiga A.H. and Funamizu N. (2014) Inactivation mechanisms of pathogenic bacteria in several matrixes during the composting process in a composting toilet. *Environmental Technology*, 35: 674-680. [doi.org/10.1080/09593330.2013.841268](https://doi.org/10.1080/09593330.2013.841268)
3. **Sossou S. K.**, Sou/Dakoure M., Hijikata N., Maiga A. H. and Funamizu N. (2015) Inactivation kinetics of indicator microorganisms during solar heat treatment for sanitizing compost from composting toilet. *Journal of Water and Environment Technology*. [In press]

Published papers were reprinted with permission from the publishers.

## ACKNOWLEDGMENTS

I would like to express my sincere gratitude to all people who have contributed to this thesis. From this opportunity i have the pleasure to thank the following persons:

Professor Naoyuki FUNAMIZU for accepting supervised this work, his valuable guidance, expert advice, strong scientific support and immense knowledge. I would like to express to him my sincere gratitude;

Professor Amadou Hama MAIGA, General Director of 2iE, for have allowed and support this work, his encouragement and financial support. I would like to express to him my sincere gratitude;

Dr. Mariam SOU/DAKOURE and Dr. Nowaki HIJIKATA for have been the main co-authors of great contribution for papers published in this work. I have really appreciated their kind cooperation;

Dr. Ryusei ITO and Dr. Ken USHIJIMA of Hokkaido University for their usefull advices and great assistance;

Professor Hamma YACOUBA, director of research at 2iE and Professor Harouna KARAMBIRI, director of doctoral studies at 2iE, for their support and facilitation;

Dr. Yacouba KONATE, Head of the Laboratory of Water, Sanitation, Ecosystem and Health (LEDES) for his good management and great assistance;

My colleagues: Boukary SAWADOGO, David MOYENGA, Ynoussa MAIGA, Hamidatou DARIMANI, Drissa SANGARE and Yuichi KUMAGAI for their kind cooperation;

MM. Rui TEZUKA, Noel TINDOURE and Sohamai HEMA for providing considerable technical help in laboratory works;

Professor Yaovi AMEYAPOH from University of Lome, my first trainer in research for giving me the desire and motivation of research;

My special thanks go to “Ameli-Eaur” project in Burkina Faso for creating the conditions allowing me to candidate for this thesis. This research project was financially supported by SATREPS-JST/JICA, Science and Technology Research Partnership for Sustainable Development through.

Lastly but not the least, special dedicace to the following dearest persons of my family:

- my mother who have accepted to make me a son,
- my father who have accepted to make me a man,
- my wife who have accepted to make me a husband,
- my future children who will accepted to make me a father;

My apology to those who I didn't mention in these words of acknowledgments as the words here are limited.

## TABLES OF CONTENTS

ABSTRACT .....	ii
LIST OF PUBLICATIONS .....	iv
ACKNOWLEDGMENTS.....	v
TABLES OF CONTENTS.....	vi
LIST OF FIGURES.....	x
LIST OF TABLES .....	xi
LIST OF EQUATIONS .....	xii
Chapter 1 GENERAL INTRODUCTION AND LITERATURE REVIEW .....	1
1.1. Background.....	1
1.2. Study objectives.....	2
1.3. On-site Wastewater Differentiable Treatment Systems (OWDTS): An ecological sanitation system.....	3
1.4. Composting toilet system: a sustainable alternative to sanitation .....	4
1.4.1. Definition of composting toilet .....	4
1.4.2. Different types of composting toilet.....	4
1.4.3. Factors affecting composting process in composting toilet .....	4
1.5. Inactivation of pathogens in composting toilet.....	5
1.6. Inactivation mechanisms of pathogen organism cells in composting toilet .....	6
1.7. Post-treatment of compost for land application.....	7
1.8. Compost safety for land application .....	7
1.9. Guidelines and regulations for composting toilet.....	8
1.10. References.....	8
Chapter 2 INACTIVATION OF INTESTINAL PARASITES AND PATHOGENIC BACTERIA IN COMPOSTING TOILET DURING THE COMPOSTING PROCESS .....	12
2.1. INTRODUCTION .....	12
2.2. MATERIALS AND METHODS .....	13
2.2.1. Raw materials.....	13
2.2.3. Physicals analysis.....	14
2.2.4. Detection and enumeration of bacteria .....	14
2.2.5. Detection and enumeration of parasites .....	15
2.2.6. Viability detection of parasites .....	15

2.3. RESULTS AND DISCUSSION.....	15
2.3.1. Physical change of the organic material during composting process .....	15
2.3.2. Reduction of bacteria and spores during composting process .....	17
2.3.3. Predominance of helminths eggs and protozoan cysts in feces collected.....	18
2.3.4. Removal dynamics of <i>Ascaris lumbricoides</i> eggs and <i>Entamoeba hystolitica</i> cysts during composting process .....	19
2.3.5. Viability reduction of <i>Ascaris</i> eggs and <i>Entamoeba</i> cysts during composting process.....	20
2.3.5. Discussion .....	21
2.4. CONCLUSION .....	22
2.5. REFERENCES .....	22
Chapter 3 <u>I</u> NACTIVATION MECHANISMS OF PATHOGENIC BACTERIA CELLS IN COMPOSTING TOILET DURING THE COMPOSTING PROCESS .....	28
INTRODUCTION .....	28
3.1. MATERIAL AND METHODS.....	29
3.1.1. Matrix, feces and compost .....	29
3.1.2. Bacteria incubation and sampling .....	29
3.1.3. Bacteria extraction and measurement .....	29
3.1.4. Bacteria damage estimation .....	30
3.1.5. Statistical analysis .....	30
3.1. RESULTS AND DISCUSSION.....	30
3.1.1. Survival ratio of <i>E. coli</i> in three matrixes .....	30
3.1.2. Inactivation rate constant of <i>E. coli</i> in three matrixes.....	32
3.1.3. Mechanisms of damaging components of <i>E. coli</i> during matrix change .....	32
3.1.4. Mechanisms of damaging components of <i>E. coli</i> during pH change.....	33
3.1.5. Discussion .....	34
3.2. CONCLUSION .....	35
3.3. REFERENCES .....	36
Chapter 4 <u>H</u> YGIENIC QUALITY OF FRESH AND STORED COMPOSTS FROM COMPOSTING TOILET .....	39
4.1. INTRODUCTION .....	39
4.2. MATERIAL AND METHODS.....	39



4.2.1. Collection and preparation of compost samples .....	39
4.2.2. Storage treatment set up.....	40
4.2.3. Physico-chemical parameters before and after storage treatments .....	40
4.2.4. Microbiological analysis of fresh and stored compost .....	40
4.2.5. Statistical analysis .....	41
4.3. RESULTS AND DISCUSSION.....	41
4.3.1. Physico-chemical property change of compost during storage .....	41
4.3.2. Hygienic quality of fresh and stored composts .....	42
4.3.3. Health implications of microbial population in fresh and stored composts.....	43
4.4. CONCLUSION .....	44
4.5. REFERENCES .....	45

**Chapter 5 POST-TREATMENT BY SOLAR HEATING FOR SANITIZING COMPOST FROM COMPOSTING TOILET..... 47**

5.1. INTRODUCTION .....	47
5.2. MATERIAL AND METHODS.....	48
5.2.1. Compost collection .....	48
5.2.2. Collection of microorganisms and suspension preparation .....	48
5.2.3. Solar heat treatment set up .....	49
5.2.4. Sampling .....	49
5.2.5. Microbiological analysis .....	50
5.2.6. Physico-chemical analysis .....	50
5.2.7. Climatic conditions monitoring .....	50
5.2.8. Data analysis .....	50
5.3. RESULTS AND DISCUSSION.....	51
5.3.1. Parameters monitoring during solar heating .....	51
5.3.2. Physico-chemical property change of compost during solar heating .....	53
5.3.3. Change of indicator microorganisms during solar heating .....	54
5.3.4. Inactivation rate and decay of microorganisms during solar heating .....	56
5.3.5. Discussion .....	57
5.4. CONCLUSION .....	59
5.5. REFERENCES .....	60

Chapter 6 POST-TREATMENT BY UREA ADDITION FOR SANITIZING COMPOST FROM COMPOSTING TOILET.....	64
6.1. INTRODUCTION .....	64
6.2. MATERIALS AND METHODS .....	65
6.2.1. Compost collection .....	65
6.2.2. Microbial suspension preparation .....	65
6.2.3. Urea treatment set up .....	66
6.2.4. Measurements of pH and aqueous ammonia (NH <sub>3</sub> (aq)) .....	66
6.2.5. Measurements of indicator microorganisms .....	66
6.2.6. Data analysis .....	67
6.3. RESULTS AND DISCUSSION.....	67
6.3.1. pH and ammonia in the compost during urea treatment at different concentrations .....	67
6.3.2. pH and ammonia in the compost during urea treatment at different temperatures .....	69
6.3.3. Survival of indicator microorganisms in compost during urea treatment at different urea concentrations .....	70
6.3.4. Survival of indicator microorganisms in compost during urea treatment at different temperatures .....	72
6.3.5. Inactivation rate and decay of microorganisms in compost during urea treatment at different concentrations and temperatures .....	72
6.4. CONCLUSION .....	77
6.5. REFERENCES .....	78
 Chapter 7 GENERAL CONCLUSIONS AND FUTURE STUDIES.....	 81

## APPENDIX

## LIST OF FIGURES

Figure 2. 1. Bioreactor used .....	14
Figure 2. 2. Temperature (°C) change during composting days .....	16
Figure 2. 3. Moisture content (%) change during composting days .....	17
Figure 2. 4. pH change during composting days.....	17
Figure 2. 5. Reduction of bacteria and spores during composting process .....	18
Figure 2. 6. Removal dynamics of <i>Ascaris</i> eggs and <i>Entamoeba</i> cysts during composting process.....	20
Figure 2. 7. Viability reduction of <i>Ascaris</i> eggs and <i>Entamoeba</i> cysts during composting process.....	21
Figure 3. 1. Change in the concentration of <i>E. coli</i> in three matrixes on three media .....	31
Figure 3. 2. Inactivation rate constant of <i>E. coli</i> in three matrixes .....	32
Figure 3. 3. Inactivation rate constants by each media in different matrixes.....	33
Figure 3. 4. pH in each matrix (sawdust, rice husk, charcoal) during composting process .....	34
Figure 4. 1. Schematic diagram of composting toilet with continuously supply of feces .....	40
Figure 5. 1. Solar box used.....	49
Figure 5. 2. Ambient temperature and temperature in compost during sunlight heating.....	52
Figure 5. 3. Ambient temperature and temperature in compost during solar box heating.....	53
Figure 5. 4. Change of <i>E. coli</i> during solar heating .....	55
Figure 5. 5. Change of <i>E. faecalis</i> during solar heating .....	55
Figure 5. 6. Change of <i>Ascaris</i> eggs during solar heating.....	56
Figure 6. 1. Change of pH values during urea treatment at different urea concentrations .....	68
Figure 6. 2. Change of ammonia concentrations during urea treatment at different urea concentrations.....	68
Figure 6. 3. Change of pH values during urea treatment at different temperatures .....	69
Figure 6. 4. Change of ammonia concentrations during urea treatment at different temperatures .....	70
Figure 6. 5. Change of <i>E. coli</i> during urea treatment .....	71
Figure 6. 6. Change of <i>Ascaris</i> eggs during urea treatment .....	72

## LIST OF TABLES

Table 1. 1. Physicochemical and biological factors that affect the inactivation of microorganisms in the environment.....	6
Table 2. 1. Predominance of helminths eggs and protozoan cysts in feces collected .....	19
Table 3. 1. Assumed damages on <i>E. coli</i> which result in undetection for each medium.....	30
Table 3. 2. Estimated parts of <i>E. coli</i> damage according to the detection differences among the three media .....	33
Table 4. 1. Physico-chemical property change during compost storage .....	42
Table 4. 2. Microbiological analysis fresh and stored composts .....	42
Table 5. 1. Physico-chemical property change during compost solar heating.....	53
Table 5. 2. Estimated maximum inactivation rate constant ( $k_{max}$ ), decimal decay rate (T90) and root-mean-square error (RMSE) of regression lines for microorganisms.....	56
Table 6. 1. Maximum inactivation rate constant ( $k_{max}$ ) and decimal decay rate (T90) of regression lines of microorganisms during urea treatment .....	73

## LIST OF EQUATIONS

Equation 3. 1 .....	31
Equation 5. 1 .....	51
Equation 5. 2 .....	51
Equation 6. 1 .....	67
Equation 6. 2 .....	67

## Chapter 1

### GENERAL INTRODUCTION AND LITERATURE REVIEW

#### 1.1. Background

World-wide, 2.6 billion people are estimated to defecate in open or unsanitary places (WHO and UNICEF, 2012). The lack of adequate sanitary installations and proper sanitary waste disposal systems leads to serious implications on human and environment health (Lopez Zavala et al., 2002). Improved sanitation has become an issue global importance, highlighted by the UN Millennium Development Goal (MDG) who target to 'halve by 2015 the proportion of people without access to basic sanitation'. However, one speculation has shown a difficulty of the MDG achievement in developing countries (WHO and UNICEF, 2012). In order to overcome the difficulty, small foot printed and resource recycling based sanitation system such as On-site Wastewater Differentiable Treatment System (OWDTS) (Lopez Zavala et al., 2002) and Ecological Sanitation (Esrey et al., 1998) has been proposed. In these concepts, wastewater from a household is fractioned to feces, urine and grey water to reuse as agricultural materials after adequate treatment with simple facilities. Therefore OWDTS system, based on the concept "don't collect" and "don't mixed" is a promising decentralized treatments system adapted for both develop and developing countries because of its low cost, no energy requirement and easy to operate and maintain (Lopez et al. 2002).

Composting is a naturally occurring aerobic process, whereby native microorganisms convert mainly biodegradable organic matter to carbon dioxide and ammonium under aerobic condition (Lopez Zavala et al. 2004; Hotta and Funamizu 2007) and residue remained as humus like compounds. A composting toilet, which is one of a key technology of the OWDTS, uses several matrixes as a bulking agent for bioconversion of human excreta into compost which can be used either as organic fertilizer rich in N, P, and K, or as a soil conditioner (Kitsui and Terazawa 1999; Del Porto and Steinfeld, 2000). The composting toilet does not require water or drainage compared with a flush toilet, therefore can preserve water resources (Winblad et al. 2004) and introducing with inexpensive investment (Ushijima et al., 2011). Taking these advantages, the practical application has been attempted in rural Japan under mesothermal climate (Ito et al., 2006), urban slum in Indonesia under tropical rainy climate (Ushijima et al., 2007) and rural area in Burkina Faso under tropical dry climate (Ushijima et al., 2012).

Although proper composting can kill human pathogens in different types of compost (Redlinger et al., 2001), a composting toilet has a potential to trap pathogens derived from infected persons (Otaki et al. 2007). This pathogens destruction in composting toilet depends on temperature, pH, moisture and storage time (Mehl et al., 2011). Several studies reported the removal of pathogenic bacteria (Tønner-Klank et al., 2007) and virus (Kazama et al., 2011) in composting toilet, but the removal of parasites (helminthes eggs and protozoan cysts) have not been so far studies. In addition, the removal of helminthes eggs among parasites from biosolids is not so extended to that of protozoan cyst in some developing countries because all medical regulation focuses only to drugs anti-helminthes. Therefore, care should

be taken when producing and using this compost especially since parasites tend to have stronger resistance than pathogenic bacteria and viruses.

Even the removal of pathogenic bacteria during composting have been studied, the damage mechanisms of microbial cells inactivation are not well established. To fully assess the safety of compost after composting process it is important to characterize the injury, lethal and sub-lethal damage during composting process and identify the potential re-growth of bacteria. The damage mechanisms of bacteria cells involved in a disinfection process is most commonly explained as the destruction of the organism protein structure and the inhibition of enzymatic activities as well as the nucleic acid and morphological structure (Kazama and Otaki, 2011; Maillard, 2002). So far, most research activities were focused on the investigation of bacteria damage with complex techniques using molecular methods in drinking water. Consequently, there is still a lack of simple standard method on the primary pathway of microorganisms' inactivation in compost.

The most common sanitization treatment of feces is composting, where the main inactivation of pathogens is due to increased temperature (WHO, 2006). However, in most cases, the temperature of composting toilet in developing countries, do not greatly increase to destroy all pathogens (Austin 2002; Mehl et al. 2011; Redlinger et al. 2001). Therefore, due to sanitary and epidemiological reasons, it is necessary to establish post-treatment methods which will allow constant monitoring of compost sanitization effectiveness before agriculture reuse. The most reliable methods for sanitizing fecal material are physical treatment as thermal treatment and chemical treatment as alkaline treatment. Several studies report the sanitizing of human feces (Vinnerås et al., 2003), manure (Ghaly and MacDonald, 2012) and sludge (Sypuła et al., 2013) by thermal and alkaline treatment, but the effectiveness of these systems on compost has not been studied yet.

This dissertation thesis aimed, therefore, to investigate the fate of intestinal parasites (helminthes eggs and protozoan cysts) and pathogenic bacteria in the composting toilet from the view point of hygienic risk.

## **1.2. Study objectives**

The overall objective of this thesis was to investigate the fate of intestinal parasites (helminthes eggs and protozoan cysts) and pathogenic bacteria in the composting toilet from the view point of hygienic risk.

The specific objectives of this study were:

- ✓ To investigate the removal of intestinal parasites and pathogenic bacteria in composting toilet during the composting process;
- ✓ To elucidate the inactivation mechanisms of pathogens cells in composting toilet during the composting process;
- ✓ To evaluate the sanitizing effectiveness of storage, solar heating and urea addition as post-treatment of compost from composting toilet.

### 1.3. On-site Wastewater Differentiable Treatment Systems (OWDTS): An ecological sanitation system

The Onsite Wastewater Differentiable Treatment System (OWDTS) is presented as an ecological sanitation alternative and supported by principles such as dry ecological sanitation, ecologically sustainable development; recycle of resources (water and nutrients contained in toilet wastes), conservation of water resources, public health protection and the prevention of public health risk. The OWDTS constitutes a new approach for improving the traditional onsite wastewater treatment systems and it is proposed based on a differentiable management and treatment of household wastewater effluents. Three fractions of household wastewater have been differentiated: reduced-volume black water, higher-load grey water, lower-load grey water and urine. Subsequently, to mitigate the reliance on commercial fertilizer, and built a sustainable society based on sound resource recycling and low carbon society, link agriculture and sanitation, is an holistic strategy for waste management, food security and food production. Therefore, OWDTS, which is based on the concept “don’t collect” and “don’t mixed” is a promising decentralized treatments system adapted for both develop and developing countries because of its low cost, no energy requirement and easy to operate and maintain (Lopez et al. 2002). At the household level feces, urine and grey water are properly separated and then treated before reusing in the farmland for sustainable agricultural production (Figure 1.1.)

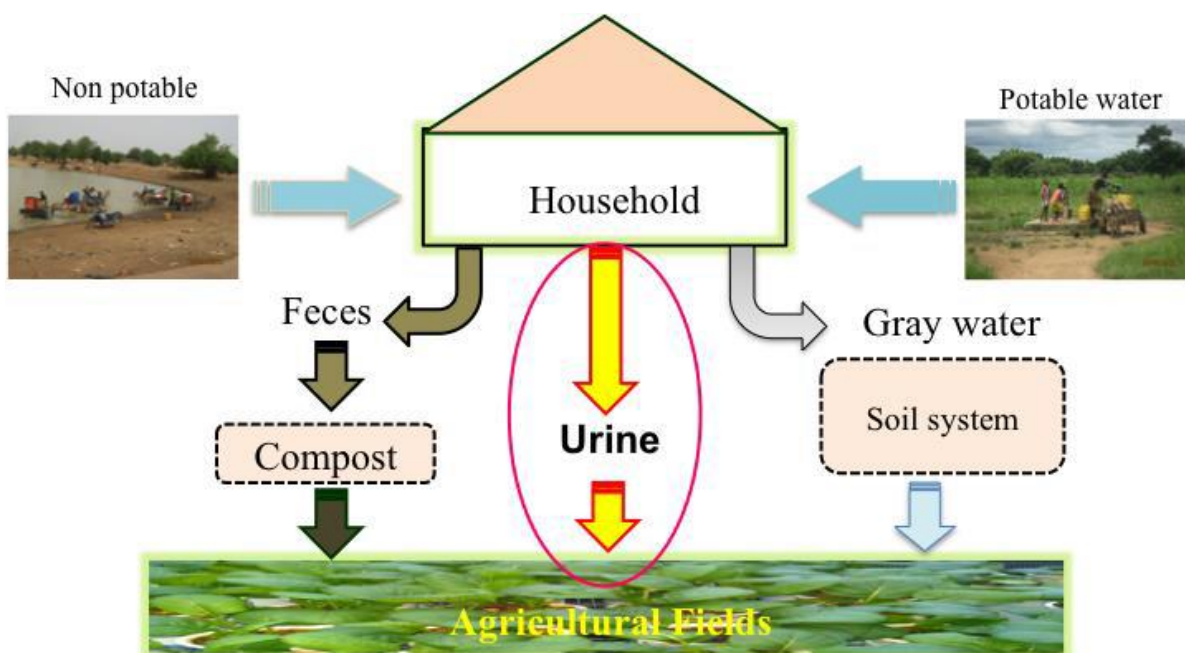

Figure 1.1. On-site Wastewater Differentiable Treatment (OWDTS) Concept



## **1.4. Composting toilet system: a sustainable alternative to sanitation**

### **1.4.1. Definition of composting toilet**

A composting toilet is a dry toilet that uses a predominantly aerobic processing system that treats human excreta, typically with no water or very small volumes of flush water, via composting or managed aerobic decomposition (Tilley et al., 2008). Composting toilets may be used as an alternative to flush toilets in situations where there is no suitable water supply or sewer system and sewage treatment plant available, or to capture nutrients in human excreta as manure. The human excreta is normally mixed with waste material (sawdust, rice husk, charcoal...) to support aerobic processing, absorb liquids, and to mitigate odor. The decomposition process is generally faster than the anaerobic decomposition used in wet sewage treatment systems such as septic tanks. Composting toilets yield a soil amendment that can be used in horticultural or agricultural applications as local regulations allow.

### **1.4.2. Different types of composting toilet**

Composting toilets are currently available in many different types of designs. The design of a composting toilet can follow any one of the paths along the lines from left to right. In other words, a composting toilet can be self-contained or central, have single or multiple chamber tanks, be operated electrically, or manually, be water-based or water-less, separately collect urine or collect urine and feces through one pipe, and be installed in single or multi-storied buildings. Therefore, there are: self-contained and central composting toilets, single and multiple chambered of composting toilets, single and multiple chambered toilets, waterless and water based toilets, electric and non-electric toilets and urine separating and combined collection systems.

### **1.4.3. Factors affecting composting process in composting toilet**

Composting is the process of decomposition of organic matter. Microorganisms oxidize organic compounds under aerobic conditions producing carbon dioxide, ammonia, volatile compounds, and water. Energy is released during decomposition some of which is used by the microorganisms for reproduction and growth; the rest is released as heat. The factors affecting the process of composting include water content, temperature, carbon to nitrogen ratio, pH, particle size, porosity, oxygen concentration. These parameters depend on the formulation of the compost mix (Bernal et al., 2009). During composting, how the process is managed by agent addition, aeration, mixing, heating, and leachate collection will affect the water content, temperature, and oxygen concentration of the compost. Most of these factors affecting composting are inter-related. Onsite recycling and wastewater treatment systems provide the treatment systems with a monitor to check liquid levels, pH levels, electric usage, and temperature (Del Porto and Steinfeld, 1998). It also has sprinkler systems for automatic liquid distribution and programmed mixers for regular mixing to aid in heat distribution. Adequate aeration is necessary to maintain aerobic conditions for composting. Moisture in compost is necessary for adequate microbial activity since the aqueous medium makes the nutrients physically and chemically accessible to micro-organisms. Different phases of composting are indicated by differing temperatures. Composting begins with and the readily degradable

organic matter is degraded by mesophilic organisms that function at a temperature range of 19-45 °C (Depledge, 2013). The pH affects the growth response of microorganisms in a compost pile. Particle size plays a role in balancing the surface area for growth of microorganisms and maintaining adequate porosity for aeration (Bernal et al., 2009).

### **1.5. Inactivation of pathogens in composting toilet**

Properly designed and maintained, composting should contain, immobilize and/or destroy pathogens, especially in a healthy population. After excretion, the concentration of enteric pathogens usually declines with time by death or loss of infectivity of a proportion of the organisms. Protozoa and viruses are unable to grow in the environment outside the host, thus their numbers will always decrease, whereas bacteria may multiply under favorable environmental conditions. Helminthes may need a latency period after excretion before being infective. The ability of a microorganism to survive in the environment is defined as its persistence to withstand the prevailing conditions. Often in investigations it is expressed as the total inactivation with time of the microorganism in question under specified environmental conditions. Time and prevailing conditions are the overall features affecting survival of microorganisms in the environment. Several physicochemical and biological factors have an impact, but this impact differs between microorganisms. Factors that are especially important for the reduction of enteric microorganisms are listed in Table 1.2. These factors can also be used separately or in combination with time as treatment methods to produce safe fertilizers from excreta.

Table 1. 1. Physicochemical and biological factors that affect the inactivation of microorganisms in the environment

Parameters	Influence on pathogens die-off
Temperature	Most microorganisms survive well at low temperatures (<5°C) and rapidly die-off at high temperatures (>40-50°C). This is the case in water, soil, sewage and on crops. To ensure inactivation in e.g. composting processes, temperatures around 55-65°C are needed to kill all types of pathogens (except bacterial spores) within hours (Haug, 1993).
pH	Many microorganisms are adapted to a neutral pH (7). Highly acidic or alkaline conditions will have an inactivating effect. Addition of lime to excreta in dry latrines and to sewage sludge can increase pH and will inactivate microorganisms. The speed of inactivation depends on the pH value, e.g. it is much more rapid at pH 12 than at pH 9.
Ammonia	In natural environments, ammonia (NH <sub>3</sub> ) chemically hydrolysed or produced by bacteria can be deleterious to other organisms. Added ammonia-generating chemical will also facilitate the inactivation of pathogens in e.g. excreta or sewage sludge (Vinnerås <i>et al.</i> , 2003).
Moisture	Moisture is related to the organism survival in soil and in feces. A moist soil favours the survival of microorganisms and a drying process will decrease the number of pathogens, e.g. in latrines.
Presence of other microorganisms	The survival of microorganisms is generally longer in material that has been sterilized than in an environmental sample containing other organisms. Organisms may affect each other by predation, release of antagonistic substances or competition (see Nutrients below).
Nutrients	If nutrients are available and other conditions are favorable, bacteria may grow in the environment. Enteric bacteria adapted to the gastrointestinal tract are not always capable of competing with indigenous organisms for the scarce nutrients, limiting their ability to reproduce and survive in the environment.
Other factors	Microbial activity is dependent on oxygen availability. In soil, the particle size and permeability will impact the microbial survival. In soil as well as in sewage and water environments, various organic and inorganic chemical compounds may affect the survival of microorganisms.

### 1.6. Inactivation mechanisms of pathogen organism cells in composting toilet

The decay mechanism of pathogens organism cells in composting is well defined by time-temperature inactivation. The damage mechanisms of bacteria cells involved in a disinfection process is most commonly explained as the destruction of the organism protein structure and the inhibition of enzymatic activities as well as the nucleic acid and morphological structure (Kazama and Otaki, 2011; Maillard, 2002). For bacteria, it is generally demonstrated that the

increase of temperature during composting has a direct impact on bacteria decay due to the autolysis of bacterial cells (Lang and Smith, 2008; Romdhana et al., 2009). Although, the primary inactivation mechanisms of helminthes eggs during composting is not known, Aitken et al. (2005) and Popat et al. (2010) speculated that the primary inactivation mechanisms of helminths organism could be protein capsid denaturation. For viruses, the mainly damage was the capsid followed by the nucleic acid (Kazama and Otaki, 2011).

### **1.7. Post-treatment of compost for land application**

The number of pathogens in fecal material during storage will be reduced with time due to natural die off, without further treatment. The type of microorganism and storage conditions governs the time for reduction or elimination. The ambient temperature, pH and moisture etc. will affect the inactivation as well as biological competition. Since the conditions during storage vary, so do the die-off rates, which may make it harder to predict appropriate storage times.

Heat treatment is one of the most effective ways of killing pathogens and is the parameter used to achieve inactivation in some of the most applied processes for fecal treatment. If a temperature  $>55^{\circ}\text{C}$  has been reached for one to a few days, an efficient inactivation has occurred. The relationships between time and temperature for various pathogens have been widely accepted even though “new” pathogens have been identified and literature giving slight variations on the results has been published. Haug (1993) states that composting at  $55\text{--}60^{\circ}\text{C}$  for a day or two should be sufficient to kill essentially all pathogens.

Alkaline treatment as chemical treatment is a method used by tradition. A common alkaline method for treatment is addition of ash or lime for raising the pH combined with long-term storage. Most pathogens favor a neutral pH, i.e. around 7. A pH of 9 and above will reduce pathogen load with time, but for rapid inactivation a pH of 11-12 is desired in treatments where lime is added. The addition of ash or lime to excreta, practiced for a long time, has several benefits: it reduces the smell; it covers the material, which in turn reduces the risk for flies and improves the aesthetical conditions; it decreases the moisture content; it promotes pathogen die-off through the elevated pH effect.

### **1.8. Compost safety for land application**

One of important safety consideration with the use of compost as soil amendment or as fertilizer is its pathogen content. Compost can contain many types of pathogenic bacteria, viruses, protozoa, helminthes and fungi that can cause various diseases (Wichuk and McCartney, 2007). In some developing countries, ash has been added to compost to raise pH and kill pathogens (Vinnerås et al., 2003). For human safety, the product from a composting toilet should not have more than 200 most probable number (MNP) per gram of fecal coliform bacteria (Del Porto and Steinfeld, 1998). Since microbiological parameters are difficult to measure, temperature is often the primary criterion used to determine if the compost is safe for use as a fertilizer. For inactivation of microorganisms, a temperature of  $55\text{--}65^{\circ}\text{C}$  is required and composting at  $55^{\circ}\text{C}$  can kill *Escherichia coli*, *Listeria* and *Salmonella* spp. within three days (Grewal et al., 2006). Time-temperature combinations are

used to assess pathogen die-off. Feachem et al. (1983) suggested time–temperature combinations of 1 h at 62°C, 1 day at 50°C, and 1 week at 46°C for pathogens to die-off in composting human waste. Depledge (1997) reported that one month of 44°C temperature or 12 months of 43°C temperature can be sufficient to kill all pathogens.

### **1.9. Guidelines and regulations for composting toilet**

There are no regulations specifically for decentralized human compost. However, there are time-temperature regulatory criteria for pathogen reduction in compost (biosolids) obtained from domestic wastewater treatment. Biosolids are classified as Class A if they do not contain detectable levels of pathogens (USEPA, 2012). USEPA requires a minimum temperature of 55°C for 15 days or longer and minimum of 5 turnings for windrow composting of Class A biosolids (USEPA, 1999a,b). For aerated static piles and in-vessel reactors the class A biosolids have to maintain a temperature greater than 55°C for 3 days. While temperature–time criteria can be used as a measure of safety of the compost, this criterion is virtually impossible to measure with available technology for the entire compost. The compost is expected to have non-uniform temperature profile (with higher temperatures in the middle due to higher microbial activity there) but only a limited number of measurements can be taken from throughout the compost. Zavala and Funamizu (2006) suggest that the compost infection risk can be reduced to an acceptable level by mixing the sawdust amended compost 20 times per day over 2 days or by mixing 15 times per day over three days after the last using event of the toilet. The mixing helps to maintain uniform temperatures and thus reduce the pathogens via advancing the process of composting.

### **1.10. References**

- Aitken, M. D., Sobsey, M. D., Blauth, K. E., Shehee M., Crunk P. L. and Walters G. W. (2005) Inactivation of *Ascaris suum* and poliovirus in biosolids under thermophilic anaerobic digestion conditions. *Environmental Science and Technology*, 39(15), 5804–5809.
- Austin, A. (2002) Urine-diversion Ecological Sanitation Systems in South Africa. CSIR, Pretoria, South Africa.
- Bernal, M.P., Albuquerque, J.A., Moral, R., (2009) Composting of animal manures and chemical criteria for compost maturity assessment. A review. *Bioresource Technology*, 100, 5444–5453.
- Del Porto, D. and Steinfeld, C. (1998) Operating and Maintaining your Composting Toilet System. *The Composting Toilet System Book*.
- Depledge, D. (1997) Design Examples of Waterless Composting Toilets. *South Pacific Applied Geoscience Commission*. Report 249.
- Esrey, S.A., Gough, J., Rapaport, D., Sawyer, R., Simpson-Hébert, M., Vargas, J. and Winblad, U. (1998) Ecological Sanitation. SIDA, Stockholm, Sweden.

- Ghaly, A. E. and MacDonald K. N. (2012) An effective passive solar dryer for thin layer drying of poultry manure. *American Journal of Engineering and Applied Sciences*, 5, 136-150.
- Grewal, S.K., Rajeev, S., Sreevatsan, S. and Fredrick, C.M. (2006) Persistence of *Mycobacterium avium subsp. paratuberculosis* and Other Zoonotic Pathogens during simulated composting, manure packing, and liquid storage of dairy manure. *Applied and Environmental Microbiology*, 72, 565–574.
- Haug, R. (1993) *The Practical Handbook of Compost Engineering*. Lewis Publishers.
- Hotta, S. and Funamizu, N. (2007) Biodegradability of fecal nitrogen in composting process. *Bioresource Technology*, 98, 3412-3414.
- Ito R., Funamizu N. and Yokota M. (2006) Energy analysis of composting toilet from full scale demonstration project on onsite differentiable treatment system for annual operation. *Proceedings of the 4<sup>th</sup> International Symposium on Sustainable Sanitation*, pp 313-321.
- Kazama, S. and Otaki, M. (2011) Mechanisms for the inactivation of bacteria and viruses in sawdust used in composting toilet. *Journal of Water and Environmental Technology*, 9, 53-66.
- Kazama, S., Nakagawa, N. and Otaki, M. (2011) A fate model of pathogenic viruses in a composting toilet based on coliphage inactivation. *Journal of Environmental Sciences*, 23, 1194-1198.
- Kitsui, T. and Terazawa, M. (1999) Environmentally-friendly toilets for the 21st century, Biotoilet. *Proceedings of the 10th ISWPC*, at Yokohama 3, pp 120-121.
- Lang N. L. and Smith S. R. (2008) Time and temperature inactivation kinetics of enteric bacteria relevant to sewage sludge treatment processes for agricultural use. *Water Research*, 42(8), 2229-2241.
- Lopez Zavala, M. A., Funamizu, N. and Takakuwa, T. (2004) Temperature effect on aerobic biodegradation of feces using sawdust as a matrix. *Water Research*, 38, 2406-2416.
- Lopez Zavala, M. A., Funamizu, N. and Takakuwa, T. (2002) Onsite wastewater differentiable treatment system: Modelling approach, *Water Science and Technology*, 46, 317–324.
- Maillard, J. Y. (2002) Bacterial target sites for biocide action. *Journal of applied microbiology*, 92(s1), 16S-27S.
- Mehl, J., Kaiser, J., Hurtado, D., Gibson, D., Izurieta, R. and Mihelcic, J. (2011) Pathogen destruction and solids decomposition in composting latrines: study of fundamental

- mechanisms and user operation in rural Panama. *Journal of Water and Health*, 9, 187-199.
- Otaki, M., Nakagawa, N., Kazama, S., Akaishi, F., Tameike, N. (2007) Hygienic risk assessment and control in using composting toilet. *Proceedings of the 7th international symposium on sustainable sanitation*, pp 91–98.
- Popat, S. C., Yates, M. V. and Deshusses, M. A. (2010) Kinetics of inactivation of indicator pathogens during thermophilic anaerobic digestion. *Water Research*, 44(20), 5965-5972.
- Redlinger, T., Graham, J., Corella-Barud, V. and Avitia, R. (2001) Survival of fecal coliforms in dry-composting toilets. *Applied and Environmental Microbiology*, 67, 4036-4040.
- Romdhana, M. H., Lecomte, D., Ladevie, B. and Sablayrolles, C. (2009) Monitoring of pathogenic microorganisms contamination during heat drying process of sewage sludge. *Process Safety and Environmental Protection*, 87(6), 377-386.
- Sypuła, M., Paluszak, Z., and Szala, B. (2013) Effect of Sewage Sludge Solar Drying Technology on Inactivation of Select Indicator Microorganisms. *Polish Journal of Environmental Studies*, 22(2), 533-540.
- Tilley, E., Ulrich, L., Lüthi, C., Reymond, Ph., Zurbrügg, C. (2008) Compendium of Sanitation Systems and Technologies - (2nd Revised Edition). Swiss Federal Institute of Aquatic Science and Technology (Eawag), Duebendorf, Switzerland. ISBN 978-3-906484-57-0
- Tønner-Klank, L., Møller, J., Forslund, A. and Dalsgaard, A. (2007) Microbiological assessments of compost toilets: In situ measurements and laboratory studies on the survival of fecal microbial indicators using sentinel chambers. *Waste Management*, 27, 1144-1154.
- USEPA (1999a) Water Efficiency Technology Fact Sheet: Composting Toilets. [http://water.epa.gov/aboutow/owm/upload/2005\\_07\\_14\\_comp.pdf](http://water.epa.gov/aboutow/owm/upload/2005_07_14_comp.pdf)
- USEPA (1999b) Control of Pathogens and Vector Attraction in Sewage Sludge. EPA/625/R-92/013 Revised October 1999, United States Environmental Protection Agency, Office of Research and Development, National Risk Management Laboratory, Center for Environmental Research Information, Cincinnati, OH. <http://water.epa.gov/polwaste/wastewater/treatment/biosolids/genqa.cfm>
- Ushijima K., Yabui K., Hijikata N., Ito R., Funamizu N. (2011) Development self-buildable simple composting toilet. *Proceedings of IWA aspire (USB-memory)*, October 2-6, 2011, Tokyo, Japan.

- Ushijima, K., Hijikata, N., Ito R., Funamizu, N. (2012) Effect Estimation of Dry-Toilet Application for Rural Farmer Family in Burkina Faso. *Journal of Arid Land Studies*, 22, 99–102.
- Ushijima, K., Irie, M., Sintawardani, N., Triastuti, J. and Ishikawa, T. (2007) Practical model of sustainable sanitation system for urban slum in Bandung. *Proceedings of the 5<sup>th</sup> international Symposium on Sustainable Sanitation*, pp 179-188.
- Vinnerås, B., Bjorklund, A., Jonsson, H. (2003) Thermal composting of faecal matter as treatment and possible disinfection method-laboratory-scale and pilot-scale studies. *Bioresource Technology*, 88, 47–54.
- WHO and UNICEF (2012) Progress on Sanitation and Drinking-Water 2012 update Geneva: WHO Press, [www.wssinfo.org](http://www.wssinfo.org)
- WHO (2006). Guidelines for the safe use of wastewater, excreta and greywater, Volume 4: Excreta and greywater use in agriculture, World Health Organisation, Geneva, Switzerland.
- Wichuk, K.M., McCartney, D., (2007) A review of the effectiveness of current time temperature regulations on pathogen inactivation during composting. *Journal of Environment, Engineering and Sciences*, 6, 573–586.
- Winblad, U., Hebert, M. S., Calvert P., Morgan, P., Rosemarin, A., Sawyer, R. and Xiao, J. (2004) Ecological Sanitation revised and enlarged edition. Stockholm Environment Institute, Stockholm.



## Chapter 2

### INACTIVATION OF INTESTINAL PARASITES AND PATHOGENIC BACTERIA IN COMPOSTING TOILET DURING THE COMPOSTING PROCESS

#### 2.1. INTRODUCTION

Basic sanitation for people is essential for their health livelihood and their environments. However, 1.2 billion people lack access to sanitation; the vast majority of these people live in low- and middle-income countries (WHO/UNICEF, 2012). To overcome this difficulty, small foot printed and resource recycling-based sanitation system such as On-site Wastewater Differentiable Treatment System (OWDTS) (Lopez Zavala, 2002) and Ecological Sanitation (Esrey, 1998) has been proposed. In these concepts, wastewater from a household is fractioned to feces, urine and grey water for reuse as agricultural materials after treatment with simple facilities. For sanitary disposal of feces, aerobic composting is a widely used process (Zorpas, 2008).

Composting is a naturally occurring aerobic process, whereby native microorganisms convert mainly biodegradable organic matter to carbon dioxide and ammonium under aerobic condition (Lopez Zavala et al. 2004; Hotta and Funamizu 2007) and residue remained as humus-like compounds. A composting toilet, which is one of a key technology of the OWDTs, uses several matrixes as a bulky agent for bioconversion of human excreta into compost which can be used either as organic fertilizer rich in N, P, and K, or as a soil conditioner (Kitsui and Terazawa 1999; Del Porto and Steinfeld 2000). The composting toilet does not require water or drainage compared with a flush toilet, therefore preserving water resources (Winblad et al. 2004) and introducing with inexpensive investment (Ushijima et al., 2011). Taking these advantages, the practical application has been attempted in rural Japan under mesothermal climate (Ito et al., 2006), urban slum in Indonesia under tropical rainy climate (Ushijima et al., 2007) and rural area in Burkina Faso under tropical dry climate (Ushijima et al., 2012). This system toilet is useful in environmentally sensitive areas where other toilet systems are problematic (Cocks and Van Bentum 2002).

Although proper composting can kill human pathogens in different types of compost (Redlinger et al., 2001), a composting toilet has the potential to trap pathogens derived from infected persons (Otaki et al. 2007). Pathogen destruction in composting toilet depends on temperature, pH, moisture and storage time (Mehl et al., 2011). In a composting process, the temperature may vary widely from a mesophilic condition (below 40°C) to a thermophilic condition (up to 50°C) (Grewal et al., 2006). However, in most cases, the volume of the composts is small and heat loss may easily occur. It is usually difficult to achieve a thermophilic condition without artificial heating (Lopez Zavala and Funamizu, 2006). Thus attention has been paid to the removal of pathogens under mesophilic and thermophilic conditions (Dincer et al., 2003). The main categories of pathogens found in human feces for composting toilet can be categorized as: bacteria, viruses and parasites. Among bacteria, *E coli* was considered to indicate fecal pollution and to be an indicator of the fate of fecal

pathogenic bacteria. Therefore, *E. coli* testing has been used to confirm the safety of potentially polluted systems. However, *E. coli* could not be used to monitor parasites that have strong resistance in human feces.

The use of several matrixes during the composting process did not significantly affect inactivation rate of pathogenic bacteria in a composting toilet (Sossou et al., 2014). Therefore local matrix such as shea nut shells or millet stem husk available in Burkina Faso can be used. Several studies reported the removal of pathogenic bacteria (Tønner-Klank et al., 2007) and virus (Kazama et al., 2011) in composting toilet, but the removal of parasites have not been studied thus far. Some parasites are considered to be more appropriate indicators than fecal bacteria to monitor the fate of parasites in biosolids (Jatinder and Simon, 2009). Helminthes are of special consideration, especially the eggs of *Ascaris lumbricoides*, because *A. lumbricoides* eggs are very persistent and not easily inactivate (Feachem et al., 2009; US EPA, 2008). *Ascaris* eggs have been also proven to be more resistant than protozoa cysts in biosolids (Maya et al., 2010). In addition, the removal of helminths eggs from biosolids is not so extended to that of protozoan in some developing countries because all medical regulation focuses only to drugs' anti-helminths. Therefore, the protozoan *Entamoeba cyst* may in fact be more tolerant among intestinal parasites (Haug, 1993). However, since the level concentration of protozoan cyst in an environmental sample is higher than that of *Ascaris* eggs, the recommended of *Ascaris* eggs as indicator for parasites removal has not proven effective. A few studies have demonstrated that there is potential for a protozoan cyst to survive during composting.

The aim of this study was to investigate the removal of intestinal parasites and pathogenic bacteria in a composting toilet during the composting process toilet by using shea nut shells as bulking agent.

## **2.2. MATERIALS AND METHODS**

### **2.2.1. Raw materials**

To stimulate defecation, human feces were collected daily during 30 days in a plastic bag introduced in a bucket obtained from a urine-diverted toilet installed at the university campus. The bulky matrix used was shea nut shells collected from a local shea butter processing plant. The shea nut shells were crushed manually to get a ground consistency before being used.

### **2.2.2. Experimental device and composting process**

The experimental device used in this study was a closed composting reactor as shown in Figure 2.1. This toilet, GleenLy Composting Toilet type Morino Eco-Toilet was purchased from Shout productions Company in Japan. The reactor chamber consists of a stainless steel cylinder-like mixing device with outer jacket of 105 L total volume. A hand-driven shaft with agitation plates is mounted horizontally in the reactor for mixing. A ventilation fan is set on the sidewall of the reactor to exchange the air in the reactor effectively.

A batch experiment was conducted in the 60-day composting period, which was selected as a suitable duration by preliminary experiments for all the biodegradable matters in the feces. For the experimental run, human feces and shea nut shells were mixed in a dry weight ratio of 1:4 which was found to be a proper composition for maintaining the aerobic composting condition (Bai and Wang, 2010). The total dry weight of the mixture was 30 kg. During the composting process, the mixture was sampled each fifth day from the reactor after a good mixing. The following analyses were conducted on each sample.

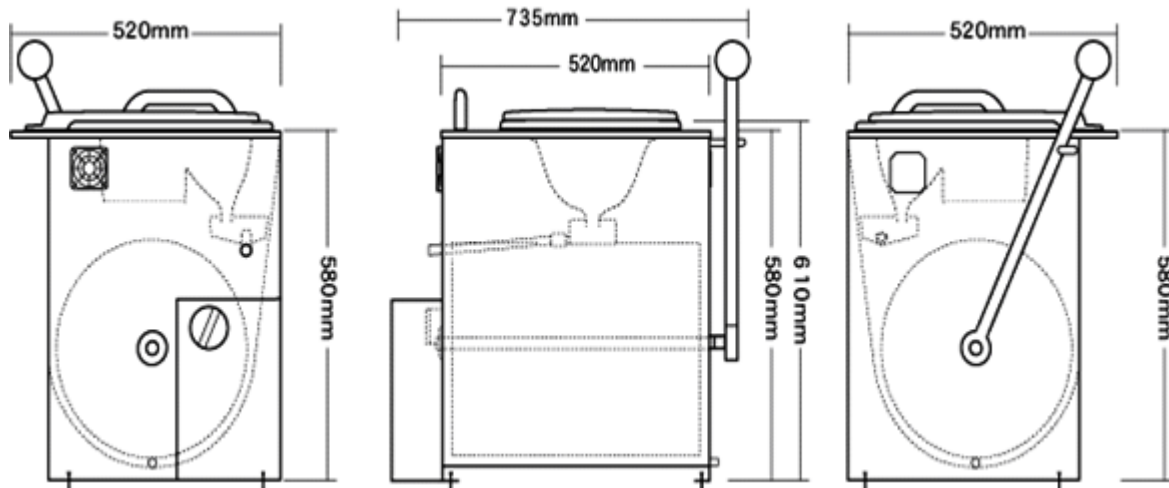

Figure 2. 1. Bioreactor used

### 2.2.3. Physicals analysis

Temperature was monitored with a digital thermometer (TPI Model 343) every 5 days during 60-day experiment. The probe was directly inserted in matrix of composting toilet and monitored. The pH was determined with a WTW handheld multi-parameter instrument 330i in compost suspension in deionized water at the ratio of 1:20 (w:v) after 30 minutes shaking. Moisture content was determined through the weight loss at 105°C by the procedures established in the Standard methods (Eaton et al., 2005).

### 2.2.4. Detection and enumeration of bacteria

Initially, 25 g (w/v) of compost samples were homogenized in 225 ml of buffered peptone water (tryptone, 10 g/L; NaCl, 5 g/L; Disodium Phosphate, 3.5 g/L; Potassium Dihydrogen Phosphate, 1.5 g/L; pH 7.2) at 1:10 (w:v) and a 10-fold dilution series was performed in maximum recovery diluent. Total coliforms, *E. coli* and *Enterococcus* were cultured following a modification of method 9215 A in Standard Methods for the Examination of Water and Wastewater (APHA, 1998). Relevant dilutions were spread on plates in duplicate on the following selective media: chromocult coliform agar ES (Difco, France) incubated at 37°C for 24 h for total coliforms and at 44,5°C for 24 h for *E. coli*, Slanetz Bartley agar at 37°C for 48 h for *Enterococcus*. Spores of sulphite-reducing clostridia (SSRC) were counted by the procedure described by Bufton (1959). Colony forming units were counted after incubation at 37°C for 24 h. Colonies were counted and the counts averaged were presented as CFU/g of the original sample using the relevant percentage water content.

The qualitative detection (presence or absence) of Salmonella in 25 g (w/v) of compost samples was performed according to 9260 B Standard Methods for the Examination of Water and Wastewater (APHA, 1998) by using both media: xylose lysine desoxycholate agar (XLD) plates (Oxoid) and brilliant green agar (Merck) containing novobiocine.

#### **2.2.5. Detection and enumeration of parasites**

Parasitological analysis was performed on feces and compost samples and was based on the recognition of forms and structure of helminths eggs and protozoa cysts in microscope. In fresh feces collected, helminths eggs and protozoan cysts were detected directly by microscopy viewing with saline solution (9% NaCl). The number of eggs or cysts per gram of feces was calculated using the relevant percentage water content. For compost analysis, sludges (compost suspension) were prepared by adding 225 ml of 0.1% Tween 80 to 25g compost sample. The mixture was homogenized for 1 min using a blender and screened through 4 layers of folded gauze compress. The filtrate was collected in round bottom flasks and allowed to settle for 3 hours and submitted to analysis. Helminth eggs were determined by the US EPA protocol (1999) modified by Schwartzbrod (2003) with a modified density of zinc sulfate saline solution. The enumeration of protozoan cysts was performed by the method of Gaspard and Schwartzbrod (1993), with a combination of sedimentation and filtration using a solution of sodium acetate formaldehyde. The number of eggs or cysts per gram of compost was calculated using the relevant percentage water content.

#### **2.2.6. Viability detection of parasites**

The viability test of helminths eggs was performed using the safranin dyeing method developed by de Victoria and Galvan (2003). After the last centrifugation and the removal of supernatant, the sample was stained by adding 50µl of Safranin O (2.5% in H<sub>2</sub>O) to the sediment. After waiting for at least 10 min, the tubes were filled with water and centrifuged at 800g for 5 min. The supernatant was poured off, the pellet re-suspended with water, and the tubes centrifuged again. The sediment was then diluted with 0.1N H<sub>2</sub>SO<sub>4</sub> and the whole eggs were counted in glass and covered glass. If the dye had penetrated into the helminths eggs they were counted as non-viable. The viability of protozoa cysts were performed by using Trypan blue dyeing method developed by Tan et al., (2010). After the last centrifugation and the removal of supernatant, the sample was mixed with 50µl of Trypan blue (0.4% in H<sub>2</sub>O) to the sediment. After 30 min, the supernatant was washed with 1X PBS every 30-min intervals for 8 h. The pellet re-suspended with water, and the tubes centrifuged at 800g for 5 min. The whole cysts were counted in glass and covered glass. If the dye had penetrated into the protozoa cysts they were counted as non-viable.

### **2.3. RESULTS AND DISCUSSION**

#### **2.3.1. Physical change of the organic material during composting process**

The physical change of the organic material during composting process was showed in Figure 2.2, 2.3 and 2.4. The temperature was started from 31,4°C, reached 35,7°C at the maximum

on 20<sup>th</sup> day and decreased to 29,7°C at the 60<sup>th</sup> day which get closer to the ambient temperature. The composting process was concluded to be mesophilic. The mean pH in the organic substrate at the beginning of the experiment was 6,65. This was increased to 9,48 at 21<sup>st</sup> day and decreased during stabilization period remaining in the alkaline zone. The moisture content is still decreasing from 22,5% the 1<sup>st</sup> day to 7,07 % the 60<sup>th</sup> day. The initial moisture content is low because shea nuts shell (7%) is a very dry material.

The main pH in the composting reactor fell within the recommended pH to promote thermophilic composting but the composting reactor temperature was mesophilic and operated under similar ambient temperature conditions. This temperature was not sufficiently elevated for an adequate amount of time to destroy pathogens. This low temperature during composting would probable due to the type of bulking agent used or the mixing frequency during composting operation. The average moisture level was under the ideal moisture level for composting material, thus it would indicate absence of intensive decomposition, which had not been evaluated in this study. To destroy pathogens by means of desiccation, moisture levels should be under 25% (WHO, 2006). It appeared that the compost was operated to destroy pathogens by means of dessiccation alone to achieve pathogen destruction by desiccation. According to previous studies (Mehl et al., 2011), the majority of composting toilet in developing countries do not reach high enough temperatures for complete pathogen destruction, thus desiccation at alkaline pH may be the primary mechanism for pathogen inactivation.

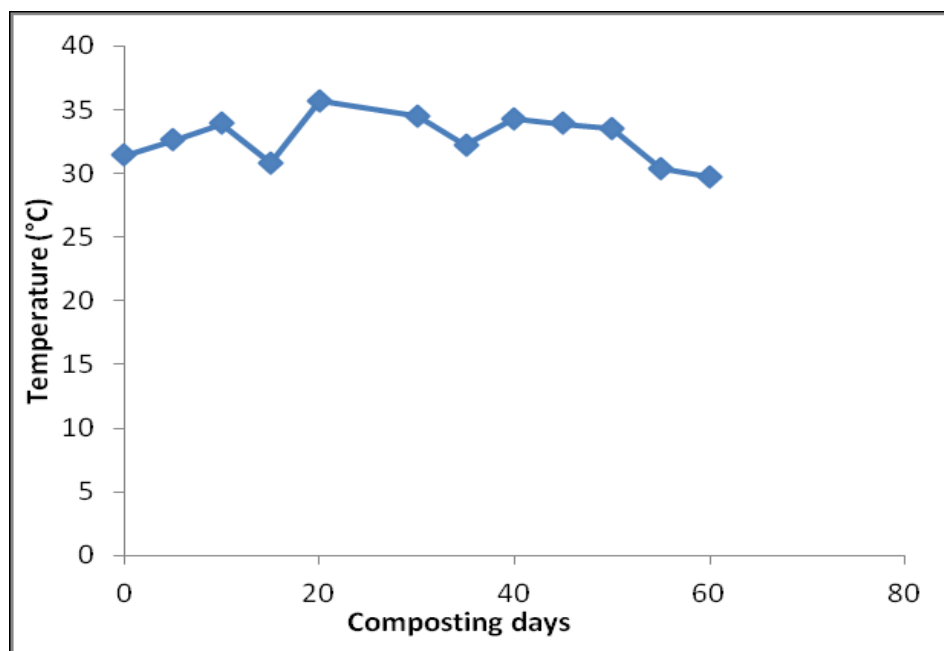

Figure 2. 2. Temperature (°C) change during composting days

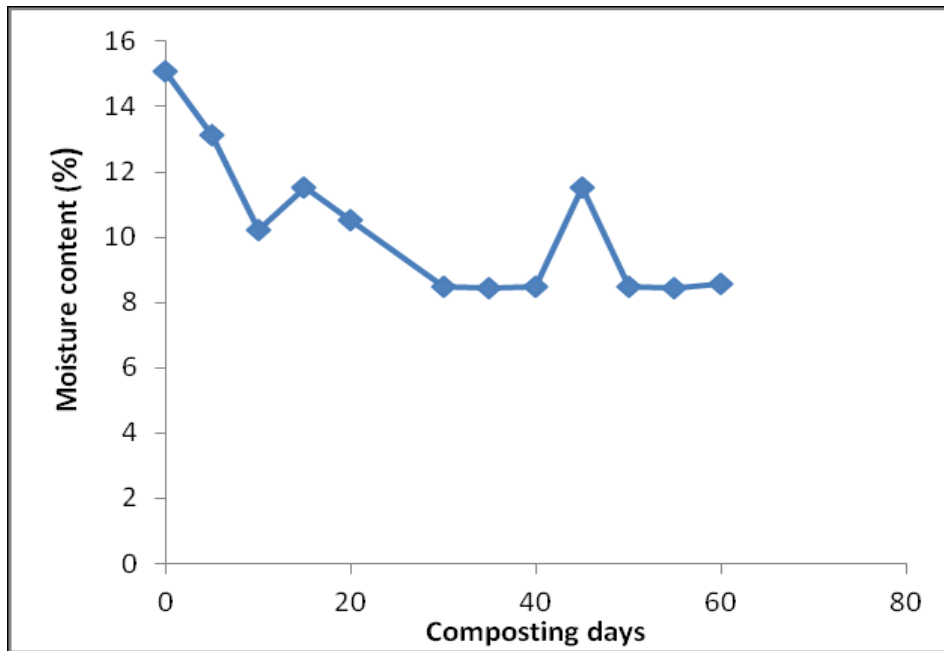

Figure 2. 3. Moisture content (%) change during composting days

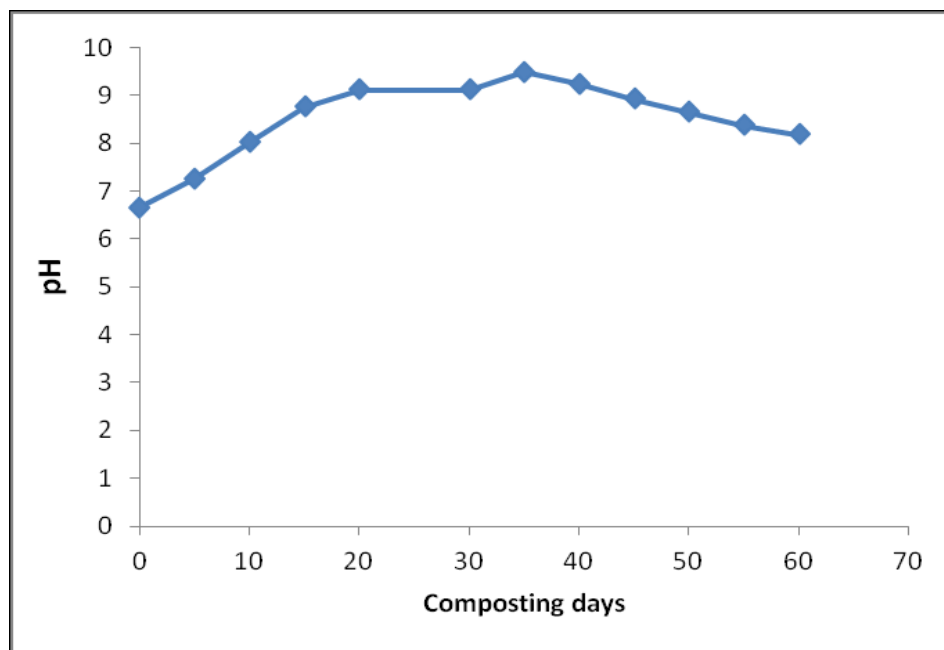

Figure 2. 4. pH change during composting days

### 2.3.2. Reduction of bacteria and spores during composting process

At the beginning of composting, *Salmonella sp* was present during the process but was undetectable after 30 days of composting. Figure 2.5 presents the reduction of total coliforms, *E. coli*, *Enterococcus* and SSRC during composting process. The high concentration of all bacteria was observed at the first day of the experiment. Those concentrations decreased progressively during all composting process period up to the 60<sup>th</sup> day. During 60 composting days, total coliforms and *E. coli* had a reduction of 2.8-log<sub>10</sub> and 2.9-log<sub>10</sub> respectively.

*Enterococcus* had 3.1-log<sub>10</sub> reduction and SSRC had 3.3-log<sub>10</sub> reduction after 60 composting days.

Indicator bacteria (total coliforms, *E. coli*, *Enterococcus* and SSRC) were present in the compost and were reduced during composting process. Only pathogenic bacteria (*Salmonella* sp.) appeared to be eliminated in compost after 30 days. *Enterococcus* was still present in compost (Christensen et al., 2002) and had observed re-growth sometimes during composting process (Zaleski et al., 2005). Spores of sulphite-reducing clostridia can survive in composting conditions that inactivate other bacteria (Jones and Martin, 2003). Both temperature and pH in the compost were not elevated significantly to reduce indicator bacteria successfully; therefore moisture levels are the only factor to support effective bacteria destruction. More than 7,2 log reduction should have be required to inactivate all bacteria. These results support the findings of other studies (Redlinger et al., 2001; Austin, 2002; Mehl et al., 2011), that temperatures of composting latrines do not get high enough to destroy all pathogens. This suggests that factors, other than temperature influence microbial counts as microbial competition and the bulking agent used (Kim et al., 2009). Pathogen destruction of bacteria at ambient temperatures (tropical conditions 20-35°C) could be improved if the contact time were increased (Cairncross and Feachem, 1993). In the other hand, desiccation is the primary mechanism for bacteria removal (Redlinger, 2001).

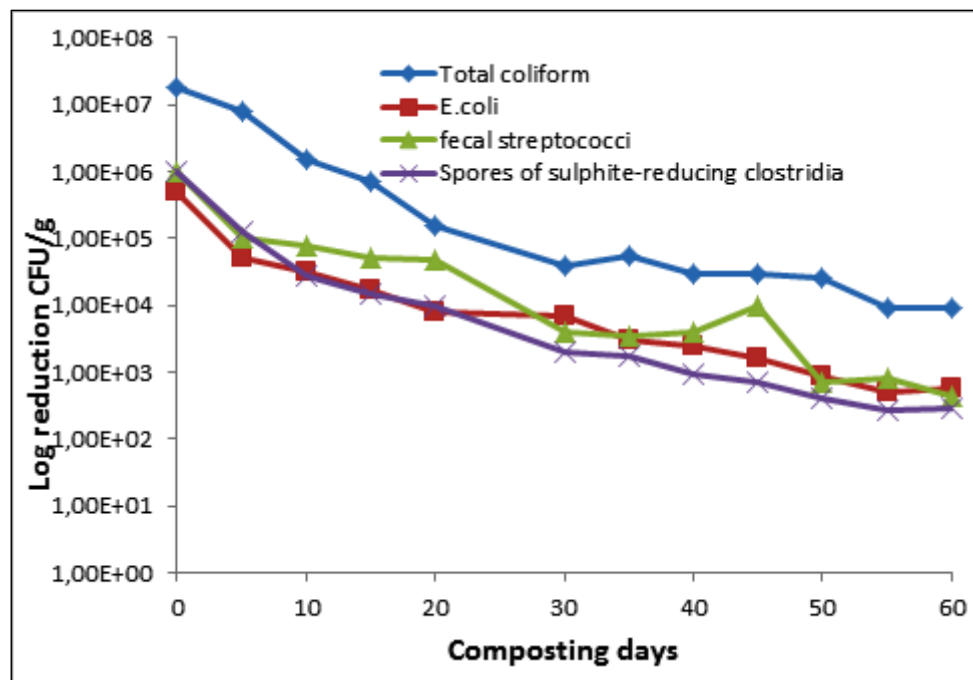

Figure 2. 5. Reduction of bacteria and spores during composting process

### 2.3.3. Predominance of helminths eggs and protozoan cysts in feces collected

The predominance of helminths eggs and protozoan cysts in raw feces collected (n=30) was presented in Table 2.1. The helminths eggs detected were represented by a mean number of *Ascaris lumbricoides* (204 eggs/g), *Trichuris trichiura* (117 eggs/g), *Ancylostoma duodenale*

(65 eggs/g), *Schistosoma mansoni* (53 eggs/g), *Hymenolepis nana* (34 eggs/g), *Enterobius vermicularis* (12 eggs/g) and *Strongyloides stercoralis* (12 eggs/g). The helminths eggs detected were those of nematode, cestode and trematode eggs. The identification of protozoan cysts has shown the presence of *Entamoeba coli*, *Entamoeba histolytica* and *Giardia lamblia* cysts which were detected at a mean concentration of 1256, 854 and 2 cyst/g, respectively. All protozoan cysts detected were those of amoeba. The results show a predominance of *Ascaris lumbricoides* among helminths eggs and *Entamoeba coli* among protozoan cysts. Protozoan cysts were in high concentration in the feces collected while helminths eggs were found in low concentration.

Table 2. 1. Predominance of helminths eggs and protozoan cysts in feces collected

<b>Parasites (n=30)</b>	<b>Min</b>	<b>Max</b>	<b>Mean ± SD</b>
<b><i>Eggs/g of helminthes</i></b>			
<i>Ascaris lumbricoides</i>	46	276	204 ± 61.54
<i>Trichuris trichiura</i>	19	163	117 ± 35.09
<i>Ancylostoma duodenale</i>	11	82	65 ± 27.64
<i>Schistosoma mansoni</i>	4	74	53 ± 13.43
<i>Hymenolepis nana</i>	0	53	34 ± 7.44
<i>Enterobius vermicularis</i>	0	21	12 ± 2.35
<i>Strongyloides stercoralis</i>	0	17	12 ± 1.04
<b><i>Cysts/g of protozoa</i></b>			
<i>Entamoeba coli</i>	950	1406	1256 ± 217.65
<i>Entamoeba histolytica</i>	740	968	854 ± 136.78
<i>Giardia lamblia</i>	0	6	2 ± 0.9

#### **2.3.4. Removal dynamics of *Ascaris lumbricoides* eggs and *Entamoeba hystolitica* cysts during composting process**

In this study, *Ascaris lumbricoides* has been used as indicator of helminths eggs because it was predominant among helminths eggs detected in feces collected and it has been proved to be the most resistant. Moreover, *Entamoeba coli* was the most predominant among protozoan cysts detected but *Entamoeba hystolitica* has been used as indicator of protozoan cysts because it is more resistant and pathogenic than *Entamoeba coli*, which is not a pathogen.

The removal dynamics of *A. lumbricoides* eggs and *E. hystolitica* cysts during composting process was shown in Figure 2.6. The number of *Ascaris* eggs was progressively reduced during composting process and was totally reduced after 35 days. The number of *Entamoeba* cysts was also progressively reduced but a total count of up to 54/g cysts was recovered after composting. The composting process was efficient to inactivate all the *Ascaris* eggs but not enough to inactivate all *Entamoeba* cysts.



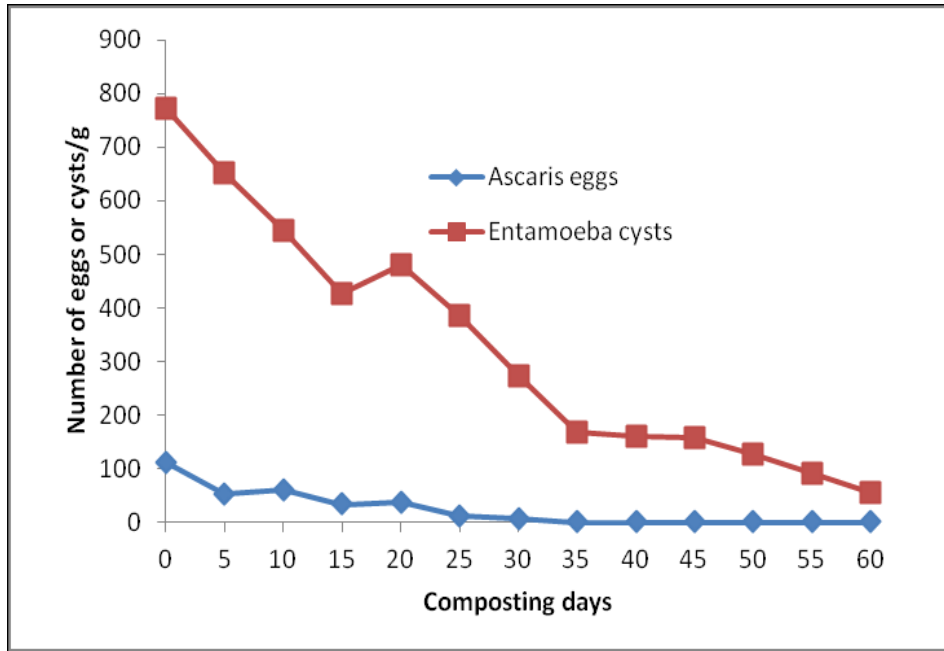

Figure 2. 6. Removal dynamics of *Ascaris* eggs and *Entamoeba* cysts during composting process

### 2.3.5. Viability reduction of *Ascaris* eggs and *Entamoeba* cysts during composting process

The viability reduction of *A. lumbricoides* eggs and *E. histolytica* cysts during composting process was shown in Figure 2.7. The viability of *Ascaris* eggs was reduced from 71% to less than 15% during 30 days, but after 30 days there were no viable *Ascaris* eggs. The viability of *Entamoeba* cysts was reduced during 60 days, but after 60 days the viability of *Entamoeba* cysts was still up to 31%.

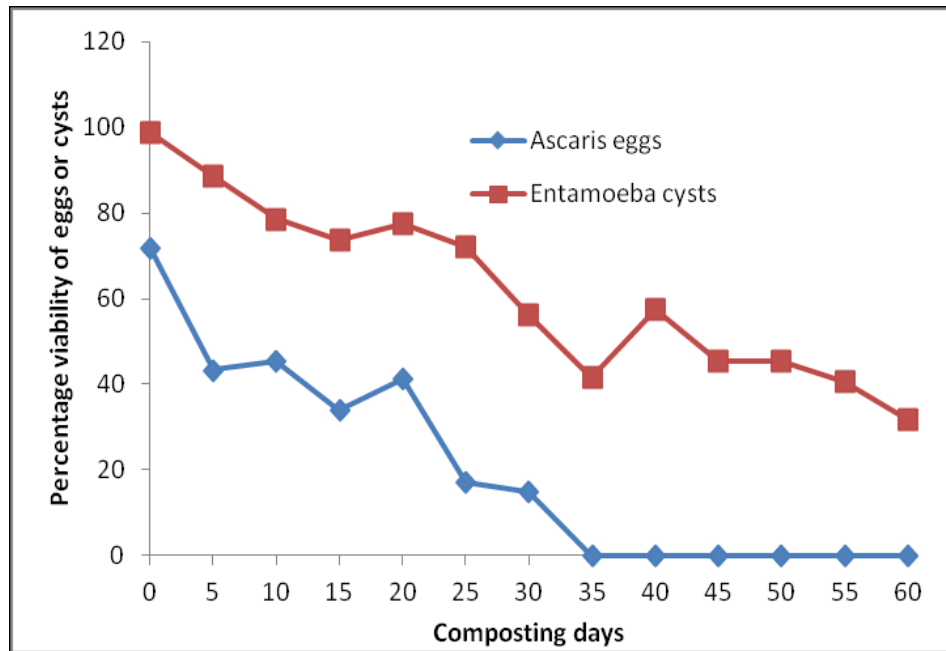

Figure 2. 7. Viability reduction of *Ascaris* eggs and *Entamoeba* cysts during composting process

### 2.3.5. Discussion

*Ascaris lumbricoides* was used to monitor the fate of helminths eggs in this study corresponding of its used as an indicator for compost quality (US EPA, 2008). *Ascaris* eggs were inactivated during composting process and deactivated early (30 days). Moe and Izurieta (2003) found on composting that temperature is the most reliable predictor for *Ascaris* inactivation, pH has minimal effect. Thus, in this study the dry conditions enable the inactivation of *Ascaris* eggs. Gaasenbeek and Borgsteede (1998) had investigated the environmental factors which lead to *Ascaris* inactivation and realized that in low temperatures, dryness was an important means of increasing inactivation. Eggs exposed to low relative humidity or dry, sunny conditions experienced greater inactivation in less time (<8 weeks) than those in high humidity and wet conditions (Collick et al., 2007). Other microbial and composting processes besides the dominating factors of temperature and reduced moisture may also be important factors responsible for inactivating *Ascaris* eggs but were not investigated during this study. Therefore, careful compost process management by the regulation of moisture content, pH, and temperature was necessary to inactivate helminthes eggs. Ongoing research is being conducted to determine the necessary temperature adjustments and relative humidity to improve the biodrying process and provide a useful dry end (Collick et al., 2007). In this study, conditions such as mesophilic temperature 30°C, alkaline pH (8-10) and moisture content (<20%), inactivation of 150 *Ascaris* eggs during 7 weeks were observed. In similar conditions, Gaasenbeek and Borgsteede (1998) had obtained 250 *Ascaris* eggs inactivation during 8 weeks in 7,5% moisture content, Eriksen et al. (1995) obtained 290 *Ascaris* eggs inactivation during 12 weeks (pH within 9-10) and Johnson et al., (1998) obtained 95% *Ascaris* eggs inactivation during 5 weeks (temperature<35°C).

*E. histolytica* was used to monitor the fate of protozoan cysts because *Entamoeba histolytica* is pathogenic and is an important intestinal infection protozoan in agriculture resource poor settings (Pham Duc et al., 2011). The number of *E. histolytica* cysts was reduced during composting process but still present in the compost at the end of the process. It is generally assumed that protozoan cysts are easily destroyed by minimal treatment or even by environmental factors such as drying but two months (60 days) at ambient temperatures is not sufficient to destroy *Entamoeba* cysts. However, it is not universally accepted that these organisms are unlikely to present a hazard in finished compost products. A few studies have demonstrated that there is potential for protozoan survival during composting. At present only one study is known to have taken into account cyst viability in compost (Van Herk et al., 2004) studied the effects of full-scale windrow composting on the viability of protozoan cysts and found that all cysts were rendered non-viable within 12 days at 55°C.

In this study, *Entamoeba* cysts have survived stronger than *Ascaris* eggs in composting process under low temperatures and dry conditions because protozoan cysts have initially high concentration in compost. Even protozoan parasites have an extremely low infective dose; a single protozoan cyst has been observed to cause infection (US EPA, 1999) so survival of even a single cyst is cause for concern. In this condition, the term ‘compost’ should be avoided for the end-product after composting process because of the inability of destroying parasites (Hill, 2013). However, in settings where human excreta are intensively used in agriculture, socio-economic and personal hygiene factors determine infection with *E. histolytica*, rather than exposure to human excreta in agricultural activities (Pham Duc et al., 2011). Even the viability and infectiveness of parasites are a distinct possibility (Itchon et al., 2007) we recommend that *E. histolytica* is one of the important criteria for safe agricultural use of this compost.

## **2.4. CONCLUSION**

This study was investigated to evaluate the removal of intestinal parasites and pathogenic bacteria in a composting toilet during the composting process by using shea nut shells as bulking agent. Low temperature, desiccation and alkaline pH were obtained during the composting process and could not completely destroy indicator bacteria. While *Salmonella* sp. was eliminated after 30 composting days. Total *Ascaris* eggs were inactivated while *Entamoeba* cysts were still present in the compost. *Entamoeba* cysts have survived stronger than *Ascaris* eggs in the end-compost and may constitute a sanitary risk when used as agricultural fertilizer. Both *Ascaris* eggs and *Entamoeba* cysts are good indicator for parasites removal.

## **2.5. REFERENCES**

- APHA (1998) Standard methods for the examination of water and wastewater. 20<sup>th</sup> ed. United Book Press, Inc., Baltimore, MD.
- Austin, A. (2002) Urine-diversion Ecological Sanitation Systems in South Africa. CSIR, Pretoria, South Africa.

- Bai, F. and Wang, X.C. (2010) Nitrogen-retaining property of compost in an aerobic thermophilic composting reactor for the sanitary disposal of human feces. *Frontiers of Environmental Science and Engineering in China*, 4, 228–234.
- Buften, A.W. (1959) A note on the enumeration of thermophilic sulphite-reducing bacteria. *Journal of Applied Bacteriology*, 22, 278-280.
- Cairncross, S. and Feachem, R.G. (1993) Environmental Health Engineering in the Tropics: An Introductory Text, Second Edition. John Wiley and Sons, Chichester. Reprinted 1999.
- Christensen, K. K., Carlbaek, M. and Kron, E. (2002) Strategies for evaluating the sanitary quality of composting. *Journal of Applied Microbiology*, 92, 1143–1158.
- Cocks, J. and Van Bentum, R. (2002) Toilet Standards for Back Country Huts (New or Replacement) Standard Operating Procedure. Unpublished draft, *Conservation Act* 1987.
- Collick, A.S, Inglis, S., Wright, P., Steenhuis, T.S. and Bowman, D.D. (2007) Inactivation of in a biodrying compost system. *Journal of Environmental Quality*, 36, 1528-1533.
- de Victorica, J. and Galvan, M. (2003) Preliminary testing of a rapid coupled methodology for quantitation/viability determination of helminths eggs in raw and treated wastewater. *Water Research*, 37, 1278–1287.
- Del Porto, D. and Steinfeld, C. (2000) The composting toilet system book. Centre for Ecological Pollution Prevention. USA. ISBN: 0-9666783-0-3
- Dincer, S., Güvenmez, H. and Çolak, Ö. (2003) Mesophilic composting of food waste and bacterial pathogen reduction. *Annals of Microbiology*, 53, 267–274. ISSN: 1590-4261
- Eaton, A. E., Clesceri, L. S., Rice, E. W. and Greenberg, A. E. (2005) Standard Methods for the Examination of Water and Wastewater. American Public Health Association, American Water Works Association, Water Environment Federation, Baltimore, MD, USA. Washington, DC, USA.
- Eriksen, L., Andreasen, P. and Ilsoe, B. (1995) Inactivation of *Ascaris suum* eggs during storage in lime treated sewage sludge. *Water Research*, 30, 1026-1029.
- Esrey, S. A., Gough, J., Rapaport, D., Sawyer, R., Simpson-Hebert, M., Vargas, J. and Winblad, U. (1998) Ecological sanitation. Sida.
- Feachem, R. G., Bradley, D. J., Garelick, H. and Mara, D. D. (1983). Sanitation and Disease: Health Aspects of Wastewater and Excreta Management. World Bank studies in water supply and sanitation. Vol. 3. New York: John Wiley and Sons.

- Gaasenbeek, C.P.H. and Borgsteede, F.H.M. (1998) Studies on the survival of *Ascaris suum* eggs under laboratory and stimulated field conditions. *Veterinary Parasitology*, 75, 227–234.
- Gaspard, P. and J. Schwartzbrod. 1993. Irrigation with Wastewater, Parasitological Analysis of Soil. *International Journal of Hygiene and Environmental Medicine*, 193, 513–520.
- Grewal, S. K., Rajeev, S., Sreevatsan, S., Michel, F. C. (2006). Persistence of *Mycobacterium avium subsp paratuberculosis* and other zoonotic pathogens during simulated composting, manure packing and liquid storage of dairy manure. *Applied and Environmental Microbiology*, 72, 565–574.
- Haug, R. (1993) *The Practical Handbook of Compost Engineering*. New York: Lewis Publishers.
- Hill, G. B., Lalander, C. and Baldwin, S. A. (2013) The Effectiveness and Safety of Vermicomposting Versus Conventional Composting of Human Feces with *Ascaris suum* Ova as Model Helminthic Parasites. *Journal of Sustainable Development*, 6, 1.
- Hotta, S. and Funamizu, N. (2007). Biodegradability of fecal nitrogen in composting process. *Bioresource Technology*, 98, 3412-3414.
- Itchon, G.S., Holner, R.J. and Tan, M.L.B. (2007) An observational study to determine the length of time necessary to eradicate parasitic ova and pathogenic bacteria in human excreta kept in storage vaults of urine diverting dehydration toilets in Cagayan de Oro City: 2007-2008: A Preliminary Report. Faculty Working Series, 11, 1-6.
- Ito, R., Funamizu, N. and Yokota, M. (2006) Energy analysis of composting toilet from full scale demonstration project on onsite differentiable treatment system for annual operation. *Proceedings of the 4th International Symposium on Sustainable Sanitation*, pp 313–321.
- Jatinder, P. S. S. and Simon, G. T. (2009) Human pathogens and their indicators in biosolids: A literature review. *Environment International*, 35, 187–201.
- Johnson, P. W., Dixon, R. and Ross, A. D. (1998) An in-vitro test for assessing the viability of *Ascaris suum* eggs exposed to various sewage treatment processes. *International Journal for Parasitology*, 28, 627–633.
- Jones, P. and M. Martin. 2003 “A review of the literature on the occurrence and survival of pathogens of animals and humans in green compost.” WRAP standards report. *The Waste and Resources Action Programme*, Oxon, United Kingdom.
- Kazama, S., Nakagawa, N. and Otaki, M. (2011) A fate model of pathogenic viruses in a composting toilet based on coliphage inactivation. *Journal of Environmental Sciences*, 23, 1194-1198.

- Kim, J., Shepherd, M. and Jiang, X. (2009) Evaluating the effect of environmental factors on pathogen regrowth in compost extract. *Microbial Ecology*, 58, 498–508.
- Kitsui, T. and Terazawa, M. (1999) Environmentally-friendly toilets for the 21st century, Biotoilet. *Proceedings of the 10th ISWPC*, at Yokohama 3, pp 120-121.
- Lopez Zavala, M. A. and Funamizu, N. (2006) Design and operation of the bio-toilet system. *Water Science and Technology*, 53, 55–61.
- Lopez Zavala, M. A., Funamizu, N. and Takakuwa, T. (2002) Onsite wastewater differentiable treatment system: Modelling approach, *Water Science and Technology*, 46, 317–324.
- Lopez Zavala, M. A., Funamizu, N. and Takakuwa, T. (2004) Temperature effect on aerobic biodegradation of feces using sawdust as a matrix. *Water Research*, 38, 2406-2416.
- Maya, C., Ortiz, M. and Jimenez, B. (2010) Viability of *Ascaris* and other helminth genera non larval eggs in different conditions of temperature, lime (pH) and humidity. *Water Science and Technology*, 62, 2616-2624.
- Mehl, J., Kaiser, J., Hurtado, D., Gibson, D., Izurieta, R. and Mihelcic, J. (2011) Pathogen destruction and solids decomposition in composting latrines: study of fundamental mechanisms and user operation in rural Panama. *Journal of Water and Health*, 9, 187-199.
- Moe, C. and Izurieta, R. (2004) Longitudinal study of double vault urine diverting toilets and solar toilets in El Salvador. *Proceedings of the 2<sup>nd</sup> International Symposium on Ecological Sanitation “Ecosan-closing the loop”*, April 2003, pp. 295–302.
- Otaki, M., Nakagawa, N., Kazama, S., Akaishi, F., Tameike, N. (2007) Hygienic risk assessment and control in using composting toilet. *Proceedings of the 7<sup>th</sup> International Symposium on Sustainable Sanitation*, pp 91–98.
- Pham Duc, P.P., Nguyen-Viet, H., Hattendorf, J., Zinsstag, J., Cam, P.D. and Odermatt, P. (2011) Risk factors for *Entamoeba histolytica* infection in an agricultural community in Hanam province, Vietnam. *Parasites and Vectors*, 4, 102.
- Redlinger, T., Graham, J., Corella-Barud, V. and Avitia, R. (2001) Survival of fecal coliforms in dry-composting toilets. *Applied and Environmental Microbiology*, 67, 4036-4040.
- Schwartzbrod, J. (2003) Quantification and Viability Determination for Helminth Eggs in Sludge (Modified US EPA Method 1999). University of Nancy, France.
- Sossou, S. K., Hijikata, N., Sou, M., Tezuka, R., Maiga, A. H. and Funamizu, N. (2014) Inactivation mechanisms of pathogenic bacteria in several matrixes during the composting process in a composting toilet. *Environmental Technology*, 25, 674-680.

- Tan, Z. N., Wong, W. K., Nik Zairi, Z., Abdullah, B., Rahmah, N., Zeehaida, M., Rumaizi, S., Lalitha, P., Tan, G. C., Olivos-Garcia, A. and Lim, B. H. (2010) Identification of *Entamoeba histolytica* trophozoites in fresh stool sample: comparison of three staining techniques and study on the viability period of the trophozoites. *Tropical Biomedicine*, 27, 79–88.
- Tønner-Klank, L., Møller, J., Forslund, A. and Dalsgaard, A. (2007) Microbiological assessments of compost toilets: In situ measurements and laboratory studies on the survival of fecal microbial indicators using sentinel chambers. *Waste Management*, 27, 1144-1154.
- US EPA (1999) Control of Pathogens of Pathogens and Vector Attraction in Sewage Sludge Environmental Regulations and Technology Cincinnati, USA: US Environmental Protection Agency, Office of Research and Development, National Risk Management Laboratory, Center for Environmental Research Information, Cincinnati, OH.
- US EPA (2008) Pathogen Equivalency Committee (PEC): Basic Information. Retrieved on October 4, 2009.
- Ushijima, K., Hijikata, N., Ito, R. and Funamizu, N. (2012) Effect estimation of dry-toilet application for rural farmer family in Burkina Faso. *Journal of Arid Land Studies*, 22, 99–102.
- Ushijima, K., Irie, M., Sintawardani, N., Triastuti, J., Ishikawa, T. (2007) Practical model of sustainable sanitation system for urban slum in Bandung. *Proceedings of the 5<sup>th</sup> International Symposium on Sustainable Sanitation*, pp 179–188.
- Ushijima, K., Yabui, K., Hijikata, N., Ito, R. and Funamizu, N. (2011) Development self-buildable simple composting toilet. *Proceedings of IWA aspire (USB-memory) Conference and Exhibition, Oct 2-6, Tokyo, Japan*.
- Van Herk, F. H., McAllister T. A., Cockwill, C. L., Guselle, N., Larney, F. J., Miller, J. J. and Olson, M. E. (2004) Inactivation of *Giardia* cysts and *Cryptosporidium* oocysts in beef feedlot manure by thermophilic windrow composting. *Compost Science and Utilization*, 12, 235-241.
- WHO (2006) Guidelines for the safe use of wastewater, excreta and greywater, Volume 4: Excreta and greywater use in agriculture, World Health Organisation. Geneva, Switzerland.
- WHO/UNICEF (2012) Progress on sanitation and drinking water 2012 update. Geneva: WHO Press [www.wssinfo.org](http://www.wssinfo.org)
- Winblad, U., Hebert, M.S., Calvert, P., Morgan, P., Rosemarin, A., Sawyer, R. and Xiao, J. (2004) Ecological Sanitation revised and enlarged edition. Stockholm Environment Institute, Stockholm.

- Zaleski K. J., Josephson, K. L., Gerba, C. P. and Pepper, I. L. (2005) Potential regrowth and recolonization of salmonellae and indicators in biosolids and biosolid-amended soil. *Applied and Environmental Microbiology*, 71, 3701-3708.
- Zorpas, A. A. and Loizido, M. (2008) Sawdust and natural zeolite as a bulking agent for improving quality of a composting product from an aerobically stabilized sewage sludge. *Bioresource Technology*, 99, 7545-7552.



## Chapter 3

### INACTIVATION MECHANISMS OF PATHOGENIC BACTERIA CELLS IN COMPOSTING TOILET DURING THE COMPOSTING PROCESS

#### INTRODUCTION

World-wide, 2.6 billion people are estimated to defecate in open or unsanitary places (WHO and UNICEF, 2012). The lack of adequate sanitary installations and proper sanitary waste disposal systems leads to serious implications on human and environment health (Lopez Zavala et al., 2002). Improved sanitation has become an issue of global importance, highlighted by the UN Millennium Development Goal (MDG) which targets to 'halve by 2015 the proportion of people without access to basic sanitation'. However, one speculation has shown a difficulty of the MDG achievement in developing countries (WHO and UNICEF, 2012). In order to overcome the difficulty, small foot printed and resource recycling-based sanitation systems such as On-site Wastewater Differentiable Treatment System (OWDTS) (Lopez Zavala et al., 2002) and ecological sanitation (Esrey et al., 1998) have been proposed. In these concepts, wastewater from a household is fractionated into feces, urine and grey water to be reused as agricultural materials after treatment with simple facilities.

A composting toilet, which is one of the key technologies of the OWDTS, has many advantages from the viewpoint of preserving water resources, allowing nutrient recycling (Winblad et al., 2004) and introducing with inexpensive investment (Ushijima et al., 2011). Taking these advantages, the practical application has been attempted in rural Japan under mesothermal climate (Ito et al., 2006), urban slum in Indonesia under tropical rainy climate (Ushijima et al., 2011) and rural area in Burkina Faso under tropical dry climate (Ushijima et al., 2011). In the composting toilet, sawdust has been frequently used as a composting matrix. The matrix plays a role of giving a gas phase for aerial fecal decomposition with little odor (Otaki et al., 2007). Besides, this aerobic decomposition subsequently raises temperature in the compost heap and the bio-generated heat accelerates evaporation of water derived from feces. To adapt the toilet all over the world, an alternative matrix is necessary because of the limitation of sawdust availability. It has been reported that chopped corn stalk, rice husk and charcoal, which were regarded as a model of the alternative matrix, showed well fecal decomposition rates in the composting toilet (Hijikata et al., 2011a) and their composts promoted vegetable growth (Hijikata et al., 2011b). However, the hygienic aspect in these alternative matrices has not been observed, so far.

A used matrix in the composting toilet has a potential to trap pathogens derived from infected persons (Sossou et al., 2011), which raises the possibility for other users or farmers to become infected (Otaki et al., 2007). Therefore, care must be taken when handling the used matrix. In the case of pathogenic bacteria, their inactivation is affected by temperature, moisture content and pH in the used matrix (Redlinger et al., 2001; Kazama and Otaki, 2011). Furthermore, the pure matrix itself contains various anti-bacterial substrates such as polyphenols, phenolic substrates and quinones (Lynch, 1993). These physical and chemical parameters might differ from matrix to matrix and stage of the composting process. Therefore, we hypothesized that inactivation and its mechanisms of pathogenic bacteria would differ with the type of matrix

and the composting process. To investigate this hypothesis, inactivation rate and estimated damage part of pathogenic bacteria in three different matrixes, which are sawdust, rice husk and charcoal from rice husk, during composting process were compared in the present study. For the investigation of bacteria, *E. coli* was used as an indicator of fecal pathogenic bacteria. Three types of media were simultaneously studied to estimate the damaging part of *E. coli*, followed by a report of Kazama and Otaki (2011).

This study aimed to elucidate the inactivation mechanisms of pathogenic bacteria cells in composting toilet during the composting process.

### **3.1. MATERIAL AND METHODS**

#### **3.1.1. Matrix, feces and compost**

Rice husk and charcoal were used as an alternative matrix of sawdust in composting toilet. In the present study, pig feces were used because its characteristic was similar to human feces (Lopez Zavala et al., 2002). The feces were continuously input into matrixes in composting machines (Hitach, Ltd. BGD-120, Kinbhoshipuro GN-120) every weekday and continued the input for 1 month and 2 months. The pure matrix or compost pH was measured after mixing with deionized water at the ratio of 1:20 (w: v).

#### **3.1.2. Bacteria incubation and sampling**

*Escherichia coli* (NBRC 3301) was used as a model microorganism of pathogenic bacteria. *E.coli* incubation was done in a growth medium Tryptic Soy Broth (Difco) and incubated in a shaking water bath at 37°C overnight. This *E. coli* suspension was used as a source of inoculums. For sample preparation an adequate aliquot of *E. coli* (0.3 mL about 10<sup>8</sup> CFU/mL) was inoculated to 3 g of autoclaved pig feces and 50 g of sterilized pure matrix or compost. The inoculated mixture was incubated at 37°C after adjusted moisture content at 50% with sterilized deionized water. The mixture was sampled at adequate time (0-8 hours after *E. coli* inoculation).

#### **3.1.3. Bacteria extraction and measurement**

The bacteria were extracted from the pure matrix or compost using a 3% (w/v) beef extraction solution (Kazama and Otaki, 2011). Beef extract (MP Biomedicals) was dissolved in deionized water, adjusted to pH 9.6 with NaOH, and sterilized. Three (3) g of the pure matrix or compost sample was added to a 20 mL volume of extraction solution and agitated for 3 minutes to extract microorganisms. After adequate dilution (10-10<sup>4</sup> times) with phosphate buffer, each extracts were inoculated in three types of agar media which were commonly used for *E. coli* detecting: Tryptic Soy Agar (TSA) (Difco), Desoxycholate Agar (DESO) (Eiken Chemical Co., Japan), and X-Gluc and Magenta-GAL (C-EC) (Compact Dry EC, Nissui pharmaceutical Co., Japan). These inoculated media were incubated at 37°C for 24 h, and then, *E. coli* colonies were counted.

### 3.1.4. Bacteria damage estimation

In order to estimate the inactivation mechanisms of *E. coli*, 3 types of media were used. According to their detection principles, the damage to *E. coli* can be assumed as shown in Table 3.1 (Kazama and otaki, 2011).

Using TSA a non selective agar, the *E. coli* which can metabolize proteins (casein and soy bean) and grow, can be detected. Therefore, when the *E. coli* growth cannot be detected on TSA, it assumed that its nucleic acid and/or its metabolic function has been damaged. DESO, a selective agar, selects for *E. coli* that can grow by metabolizing lactose in the presence of desoxycholic acid. Gram-positive bacteria are unable to grow in the presence of desoxycholic acid because they lack an outer membrane and their growth is inhibited by its surface-active effects. Therefore, when *E. coli* cannot be detected on DESO, this indicates that its outer membrane and/or, its nucleic acid and/or its metabolic function have been damaged. C-EC, a selective agar, selects for *E. coli* that produce beta-glucuronidase (the enzyme involved in the metabolism of peptone, pyruvic acid and lactose). Therefore, when *E. coli* cannot be detected on C-EC, it is assumed that its enzyme activity and/or, its nucleic acid and/or its metabolic function have been damaged. By comparing the degree of inactivation on each media, the damage part of *E. coli* could be estimated.

Table 3. 1. Assumed damages on *E. coli* which result in undetection for each medium

Media	Damages assumed
TSA	Nucleic acid and/or Metabolism
DESO	Membrane and/or Nucleic acid and/or Metabolism Enzyme activity and/or
C-EC	Nucleic acid and/or Metabolism

### 3.1.5. Statistical analysis

Analysis of variance (ANOVA) test was applied for data analysis using the StatView software version 5.0 (SAS Institute Inc., Cary, NC, USA).

## 3.1. RESULTS AND DISCUSSION

### 3.1.1. Survival ratio of *E. coli* in three matrixes

Survival ratio of *E. coli* was separately calculated with result of colony count on three types of media. According to previous studies (Otaki et al., 2007; Nakagawa et al., 2006), the inactivation of microorganisms followed a first order reaction, expressed as follows:

$$N = N_0 \cdot e^{-k \cdot t}$$

(Equation 3. 1.)

where  $N_0$  (CFU/g) and  $N$ (CFU/g) are the concentration of microorganism in matrix or compost at time 0 and  $t$  respectively,  $k$  ( $\text{h}^{-1}$ ) is the inactivation rate constant and  $t$  (h) is the retention time.

Figure 3.1 shows the survival ratio of *E. coli* in three matrixes (sawdust, rice husk, charcoal) during composting period (pure, one month and two months). The survival ratio of *E. coli* in sawdust increased from pure matrix (-2.2 to -1.8)  $\text{h}^{-1}$  to one month compost but this decreased in rice husk (-1.2 to -2.6)  $\text{h}^{-1}$  and charcoal (-1.4 to -1.6)  $\text{h}^{-1}$ . This change of survival ratio of *E. coli* was reversed in 2 month compost reaching - 2.2  $\text{h}^{-1}$ ; -2.4  $\text{h}^{-1}$  and -1.6  $\text{h}^{-1}$  for sawdust, rice husk, charcoal respectively.

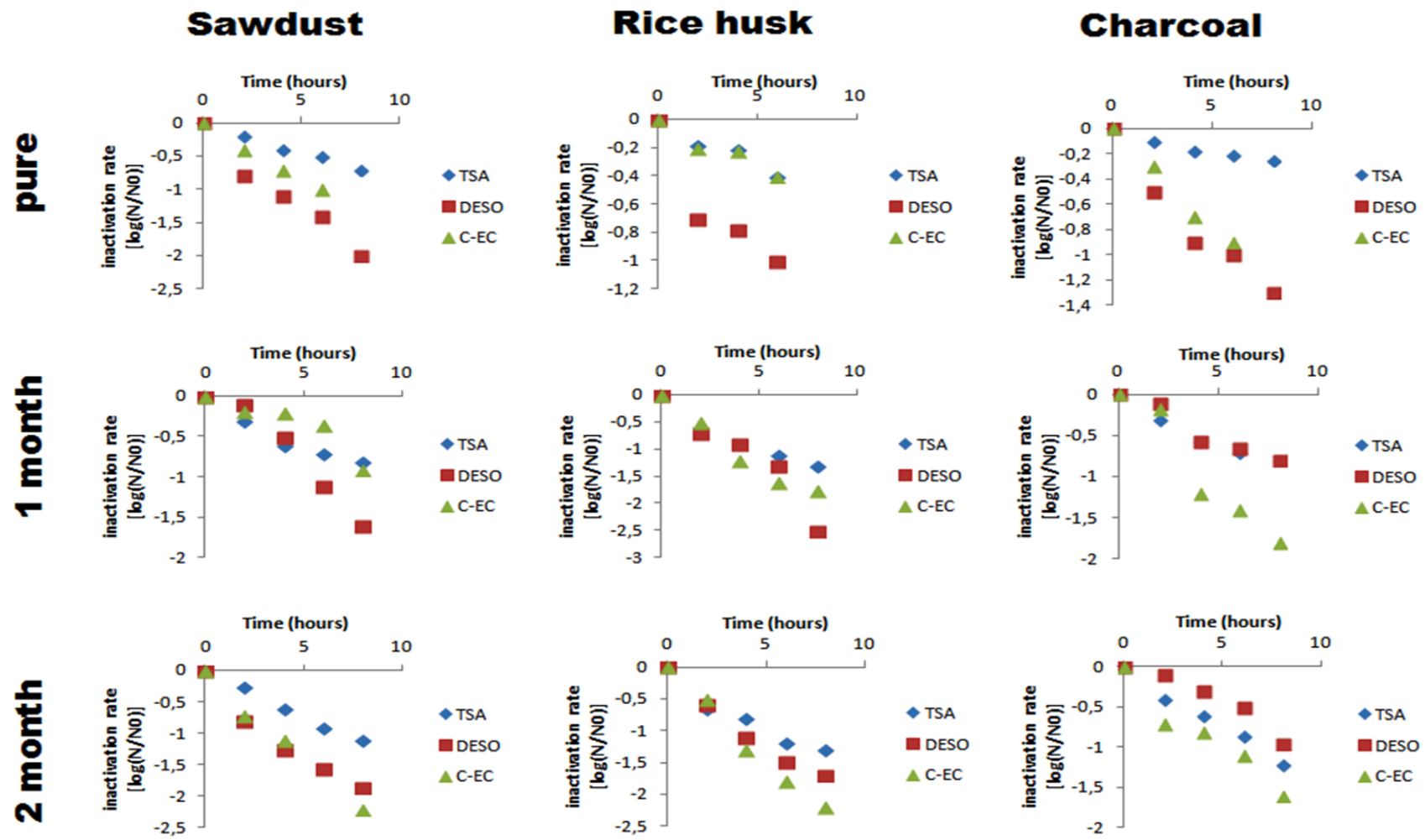

Figure 3. 1. Change in the concentration of *E. coli* in three matrixes on three media

### 3.1.2. Inactivation rate constant of *E. coli* in three matrixes

The comparison of inactivation rate constant in three matrix was done by using the value on no-selective media TSA, as representative media. Figure 3.2 shows inactivation rate constant of the three matrixes in 2 months composting. The result shows that, the inactivation rate constant was varied in each pure matrix (0.11; 0.17) h<sup>-1</sup>, compost for one month (0.12; 0.23) h<sup>-1</sup> and compost for two months (0.14; 0.24) h<sup>-1</sup>. There was no significant difference in the three matrixes (sawdust, rice husk, charcoal) during each process (pure, 1 month and 2 months). On the other hand, the value in rice husk had relatively increased during 2 months but no significant difference (ANOVA, p=0.07) was also observed.

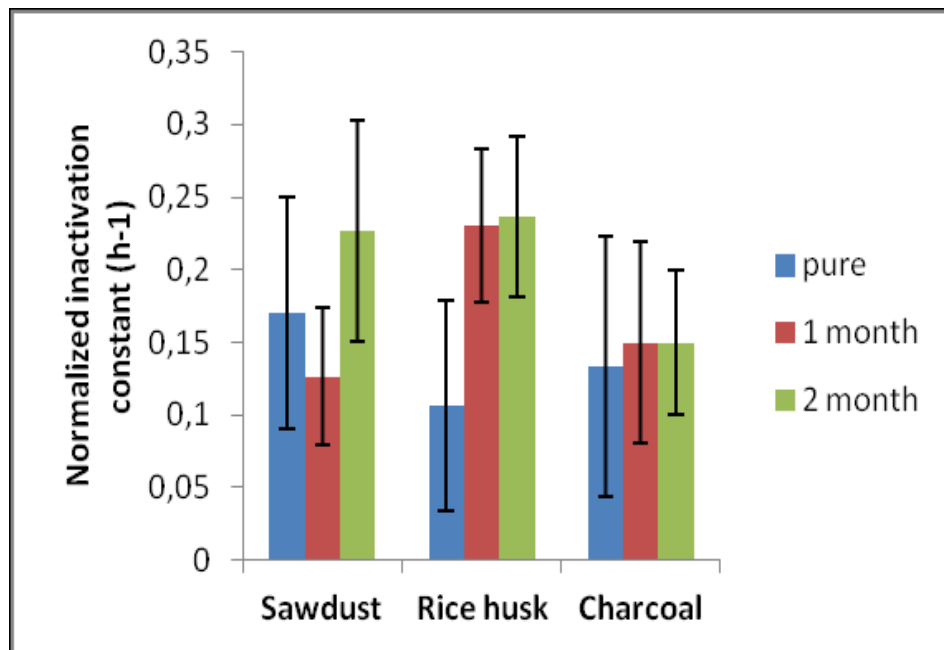

Figure 3. 2. Inactivation rate constant of *E. coli* in three matrixes

### 3.1.3. Mechanisms of damaging components of *E. coli* during matrix change

Table 2 shows the estimated damage of *E. coli* based on relative comparison of detection by three media. The damage was estimated using the difference of the inactivation rate constant by each media in Figure 3.3. In the comparison among types of matrixes, the value of TSA and C-EC in pure sawdust and pure rice husk were relatively lower than that of DESO, and the value of TSA in pure charcoal was relatively lower than that of DESO and C-EC. This indicated that damage part in pure sawdust and pure rice husk was outer membrane but in pure charcoal was outer membrane and /or enzyme activity. This estimation suggested that pure charcoal made *E. coli* more lethal damage than pure sawdust and pure rice husk. In the comparison during composting process, on the other hand, the value of C-EC in pure sawdust (0.17) and pure rice husk (0.07) increased in 2 months compost and TSA value in 2 months compost of sawdust and rice husk was relatively lower than that of C-EC and DESO. This indicated that damaging part changed from outer membrane to enzymes and/or metabolisms. In the case of charcoal, TSA value (0.03) in pure matrix is lower than that of DESO (0.18)

and C-EC (0.19), but the value increased in 2 months compost. This indicated that damaging part changed from outer membrane and enzymes into nucleic acid and/or metabolism.

Table 3. 2. Estimated parts of *E. coli* damage according to the detection differences among the three media

Media			Estimated parts which were damaged
TSA	DESO	C-EC	
X	X	X	➔ Nucleic acid and/or metabolism
O	O	X	➔ Enzyme activity
O	X	O	➔ Membrane
O	X	X	➔ Membrane and/or enzyme activity

X means culture and O means no culture

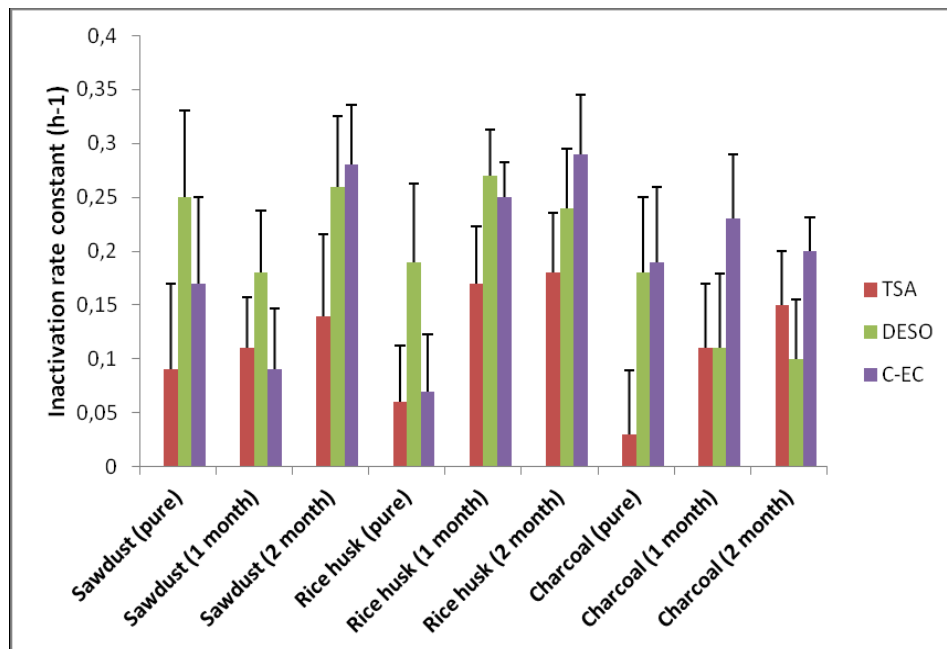

Figure 3. 3. Inactivation rate constants by each media in different matrixes

### 3.1.4. Mechanisms of damaging components of *E. coli* during pH change

The pH in each matrix (sawdust, rice husk, charcoal) during composting process (Figure 3.4) was varied and increased into alkaline zone from pure to 2 months. Pure charcoal pH was 8.32, originally higher than pure sawdust pH (7.35) and pure rice husk pH (6.34). Composted matrix pH was higher than pure matrixes and the value was (9.08 - 9.71).

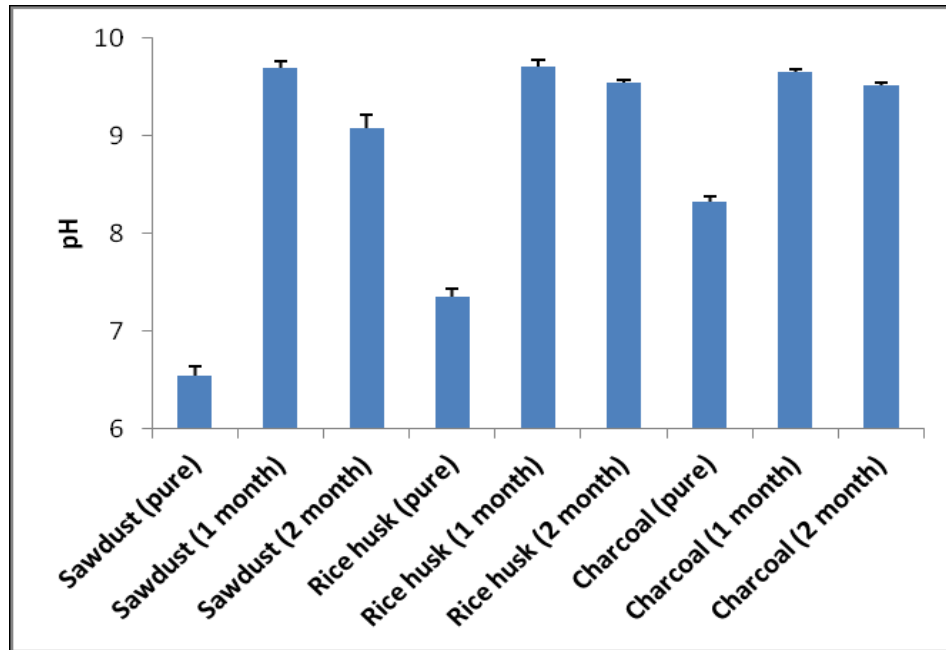

Figure 3. 4. pH in each matrix (sawdust, rice husk, charcoal) during composting process

### 3.1.5. Discussion

Inactivation rate constant of *E. coli* had no significant difference among sawdust, rice husk and charcoal during composting process (pure, one month and two months compost). It has been known that indigenous microflora of compost destroyed pathogenic bacteria (Pietronave et al., 2004). Therefore, the value of inactivation rate constant in the present study might be underestimate, since we used sterilized compost to measure *E. coli* on non-selective TSA media. Compared to a previous report with the same method (Kazama and Otaki, 2011), the values were similar to that of the report, which was 0.2 - 0.25 in sawdust compost at 37°C and 50% moisture content. This similarity implied the measurement of this study was successfully conducted. Therefore, the comparisons in the same experimental condition allow to conclude that the kinetic inactivation of pathogenic bacteria is same among the three matrixes and during composting process. However, the previous study also showed that low moisture content, high temperature and alkaline treatment caused the inactivation more significantly (Kazama and Otaki, 2011). Therefore, adequate inactivation treatment should be done for any type of matrixes, when using in a composting toilet. The way of inactivation treatment for composting toilet should be further investigated from the viewpoint of risk assessment.

On the other hand, estimated damage part was different among types of matrixes and composting process. The present results showed that pure charcoal led the bacteria to more lethal damage than pure sawdust and pure rice husk. This is probably due to the high alkaline pH of pure charcoal than others. Furthermore, composted sawdust and rice husk led the bacteria to more lethal damage than those of pure matrix. Some research works have observed re-growth of enterococci in composting toilet (Sossou et al., 2011); for example *E. coli*, fecal coliform and *Enterococcus faecalis* in source-separated household waste compost (Christensen et al. 2002). The re-growth is considered to be caused by un-lethal damage of the



bacteria. Therefore, present results suggested that adequate composting process led the pure matrix to more secure sanitation, since composted matrix showed more lethal damage than that of pure.

One reason of different damage of *E. coli* would be different pH conditions in matrixes and composts. Kazama and Otaki (2011) has reported that high pH led the pathogenic bacteria to more lethal damage. Followed by this report, pH of pure charcoal was higher than that of pure sawdust and rice husk, and pH of composted sawdust and rice husk were also higher than that of pure matrixes, in the present study. It has been known that the pure charcoal has an originally high pH because mineral is remained on its surface after carbonization (Blackwell et al., 2009). In alkaline condition, hydroxyl ions are highly oxidant free radicals that show extreme high reactivity with several biomolecules and cause lethal effects on bacterial cells. This is assumed that bacterial cytoplasmic membrane and DNA has been damage, or protein has been denatured (Siqueira and Lopes, 1999). Alkalinity can induce the solubilisation of bacterial surface proteins, resulting in exposure of hydrophobic sites of adjacent lipids to the extracellular environment (Jacobsohn, 1992). Alkali may also directly attack the structure of the cell membrane by saponification of membrane lipids or alteration of the membrane fatty acids ratio (Mendonca et al., 1994). The changes in cell surface properties and structures associated with alkali induced damage can significantly disrupt cell metabolism and structure, preventing effective growth (Almakhlafi et al., 1995). However, Mackinam et al., (2012) reported that the survival of bacteria in compost produced from rice husk charcoal is not only depend of the highly alkaline matrice but also high BET surface area and high cation exchange capacity. Hence, there are multiple mechanisms which matrixes use to damage *E. coli* in composting process and specifically charcoal has different damaging parts from other matrixes.

In the composting process, nitrogen derived from feces is ammonified (Hotta and Funamizu, 200) and this ammonification increases the compost pH. However in this study pig feces has been used without diverting urine system, therefore the larger increase of pH can indicate that the source majority of ammonia was from urine, and not organic nitrogen present in the compost McKinleya (2012). Anaerobic fecal decomposition, which is caused by inadequate air gap or too much moisture content, leads to organic acid production and this would reduce the compost pH. Therefore, choosing adequate matrix and remaining optimal condition for aerobic fecal decomposition might be essential from the viewpoint of hygienic aspect.

In this study, we investigated only *E. coli* as a model of pathogenic bacteria. Other pathogens, especially virus, those in form of spore or eggs may be less affected by inactivation in composting process. Therefore, inactivation of those more resistant pathogens must be considered.

### **3.2. CONCLUSION**

This study was undertaken to compare the inactivation rate and the mechanisms of pathogenic bacteria in three different matrixes during composting process. The results suggested that

composting matrixes (sawdust, rice husk and charcoal) and composting process did not significantly affect inactivation rate of pathogenic bacteria, however, these differences affected damaging part of the bacteria. Composting process, accompanied with pH increase, changed the damage part of bacteria more lethally. This result could help to choose matrix and time process from the viewpoint of hygienic aspect in composting toilet.

### 3.3. REFERENCES

- Almakhlafi, H., Lakamraju, M., Podhipleux, N., Singla, B. and McGuire, J. (1995) Measuring surface hydrophobicity as compared to measuring a hydrophobic effect on adhesion events. *Journal of Food Protection*, 58, 1034-1037.
- Blackwell, P., Riethmuller, G. and Collins, M. (2009) Biochar for Environmental Management: Biochar Application to Soil, earthscan, UK and USA.
- Christensen, K. K., Carlsbak, M. and Kron, E. (2002) Strategies for evaluating the sanitary quality of composting. *Journal of Applied Microbiology*, 92, 1143-1158.
- Esrey, S. A., Gough, J., Rapaport, D., Sawyer, R., Simpson-Hébert, M., Vargas, J. and Winblad, U. (1998) Ecological Sanitation. SIDA, Stockholm, Sweden.
- Hijikata, N., Yamauchi, N., Yabui K., Ushijima, K., Funamizu, N. (2011) Characterization of several agricultural wastes as a matrix of composting toilet –from fecal degradation to reuse as a soil conditioner-. *Proceeding of the 8<sup>th</sup> IWA International Symposium on Waste Management Problems in Agro-Industries*, pp 317-324.
- Hijikata, N., Yamauchi, N., Ushijima, K., Funamizu, N. (2011) Effect of bio-charcoal compost made by composting toilet for Brassica rapa var. peruviridis growth in pot cultivation. *Proceedings of the 2<sup>nd</sup> Ameli-Eaur International Workshop on Sustainable Water and Sanitation System and 8th International Symposium on Sustainable Water and Sanitation System Part I.*, pp 109-114.
- Hotta, S. and Funamizu, N. (2007) Biodegradability of fecal nitrogen in composting process, *Bioresource Technology*. 98, 3412-3414.
- Ito, R., Funamizu, N. and Yokota, M. (2006) Energy analysis of composting toilet from full scale demonstration project on onsite differentiable treatment system for annual operation. *Proceedings of the 4<sup>th</sup> International Symposium on Sustainable Sanitation*, pp 313-321.
- Jacobsohn, M. K., Lehman, M. M., Jacobsohn, G. M. (1992) Cell membranes and multilamellar vesicles influence of pH on solvent induced damage. *Lipids*. 27, 694-700.
- Kazama, S. and Otaki, M. (2011) Mechanisms for the inactivation of bacteria and viruses in sawdust used in composting toilet. *Journal of Water and Environmental Technology*, 9, 53-66.

- Lynch, J. M. (1993) Substrate availability in the production of composts. In: Hoitink, H.A.J., Keener, H.M. (Eds.), *Science and Engineering of Composting: Design, Environmental, Microbiological and Utilization Aspects*. Renaissance Publications, Ohio, 24-35.
- McKinley, W. J., Parzena, E. R., Guzmána Álvaro, M. (2012) Inactivation of *Ascaris* Ova in Ecological Compost by Using Urine and Ash, *Applied and Environmental Microbiology*, 78, 5133-5137.
- Lopez Zavala, M. A., Funamizu, N. and Takakuwa, T. (2002) Onsite wastewater differentiable treatment system: Modelling approach, *Water Science and Technology*, 46, 317–324.
- Lopez Zavala, M. A., Funamizu, N. and Takakuwa, T. (2002) Characterization of feces for describing the aerobic biodegradation of feces. *Journal of Environmental Systems and Engineering*, JSCE 720/VII-25, 99-105.
- Mackinam, T., Bachmann, R. T., Illani, Z. I., Samsuri, M. H. A. and Husni, A. W. (2012) Characterization of Local Mill Rice Husk Charcoal and Its Effect on Compost Properties. *Malaysian Journal of Soil Science*, 16, 89-102
- Mendonca, A. F, Amoroso, T. L, Knabel, S. J. (1994) Destruction of Gram negative foodborne pathogens by high pH involves disruption of the cytoplasmic membrane. *Applied and Environmental Microbiology*, 60, 4009-4014.
- Nakagawa, N., Oe, H., Otaki, M. and Ishizaki, K. (2006) Application of microbial risk assessment on a residentially-operated Bio-toilet. *Journal of Water and Health*, 4, pp. 479-486.
- Otaki, M., Nakagawa, N., Kazama, S., Akaishi, F. and Tameike, N. (2007) Hygienic risk assessment and control in using composting toilet, *Proceedings of the 7<sup>th</sup> International Symposium on Sustainable Sanitation*, pp 91-98.
- Pietronave, S., Fracchia, L., Rinaldi, M., Martinotti, M. G., (2004) Influence of biotic and abiotic factors on human pathogens in a finished compost. *Water Research*, 38, 1963-1970.
- Redlinger, T, Graham, J, Corella-Barud, V. Avitia, R., (2001) Survival of fecal coliforms in dry-composting toilets. *Applied and Environmental Microbiology*, 67, 4036-4040.
- Schaefer, M. (2008) Water technologies and the environment: ramping up by scaling down. *The Technology Society*, 30, 415–422.
- Siqueira, J. F. Jr., Lopes, H. P. (1999) Mechanisms of antimicrobial activity of calcium hydroxide: a critical review. *International Endodontic Journal*, 32, 361-369.

- Sossou, S. K., Ito, R., Jibia, A., Sou, M., Maiga, A. H. (2011) Survival of indicator bacteria and helminths eggs in composting toilet using sawdust as matrix, *Proceedings of the 2<sup>nd</sup> Ameli-Eaur International Workshop on Sustainable Water and Sanitation System and 8th International Symposium on Sustainable Water and Sanitation System Part I.*, pp 95-102.
- Ushijima, K., Yabui, K., Hijikata, N., Ito, R., Funamizu, N. (2011) Development self-buildable simple composting toilet, *Proceedings of IWA aspire (USB-memory)*, October 2-6, Tokyo, Japan.
- Ushijima, K., Irie, M., Sintawardani, N., Triastuti, J. and Ishikawa, T. (2007) Practical model of sustainable sanitation system for urban slum in Bandung. *Proceedings of the 5<sup>th</sup> International Symposium on Sustainable Sanitation*, pp 179-188.
- Ushijima, K., Hijikata, N., Ito, R., Funamizu, N. (2012) Effect Estimation of Dry-Toilet Application for Rural Farmer Family in Burkina Faso. *Journal of Arid Land Studies*, 22, 99–102.
- WHO and UNICEF (2012) Progress on Sanitation and Drinking-Water 2012 update. Geneva: WHO Press [www.wssinfo.org](http://www.wssinfo.org)
- Winblad, U., Hebert, M. S., Calvert, P., Morgan, P., Rosemarin, A., Sawyer, R. and Xiao, J. (2004) Ecological Sanitation revised and enlarged edition. Stockholm Environment Institute, Stockholm.

## Chapter 4

### HYGIENIC QUALITY OF FRESH AND STORED COMPOSTS FROM COMPOSTING TOILET

#### 4.1. INTRODUCTION

Composting is a naturally occurring aerobic process, whereby native microorganisms convert mainly biodegradable organic matter to carbon dioxide and residue, remained as humus like compounds (Lopez Zavala et al., 2004). During composting process, it is assumed that two goals are achieved: (1) the feces and bulking materials are biodegraded and transformed into organic compost, and (2) pathogens in the feces are inactivated for protection of human health. However, the most important, from the point of view of standards for the protection of public health, are those relating to the presence of pathogens (Lasaridi et al., 2006).

In most cases, the temperature in composting toilet in some decentralized area, do not get high rise to destroy all pathogens (Sossou et al., 2014a). Therefore, the main question concerning composting toilet is, whether the product, aside from being stabilized, also can be considered hygienically safe, especially when the composting toilet is continuously supply with human feces. Numerous reports demonstrate the capacity of composting toilet systems to inactivate bacteria (Sossou et al., 2014b), parasites (Sossou et al., 2014a) and viruses (Kazama et al., 2011). However, opinions differ whether composting toilet has the ability to destroy all microorganisms under detection limits (Bowman et al., 2006; Hill et al., 2013). All compost standards normally, include compost sanitization criteria for human pathogens and occasionally for plant pathogens.

One of the most reliable methods for sanitizing is storage treatment. The number of pathogens in fecal material during storage will be reduced with time due to natural die off, without further treatment. The type of microorganism and storage conditions governs the time for the reduction or the elimination. The ambient temperature as additional drying effect will affect the inactivation as well as biological competition. Since the conditions during storage vary, so do the die-off rates, which may make it harder to predict appropriate storage times.

This study aimed to evaluate the sanitization effectiveness of compost produced in composting toilet with continuous humans feces supply by storage treatment for a short time.

#### 4.2. MATERIAL AND METHODS

##### 4.2.1. Collection and preparation of compost samples

Compost samples used for the experiments were produced in an urine-diverting composting toilet with continuously feces supply. The prototype toilets were installed in some pilot families households located in two rural villages in Burkina Faso. Composts were produced with millet husk as bulking agents. A total of 8kg of compost were produced in the

composting toilet for 2 months and removed for constituted fresh compost. Before use, compost samples were mixed up to insure maximum homogeneity prior analysis.

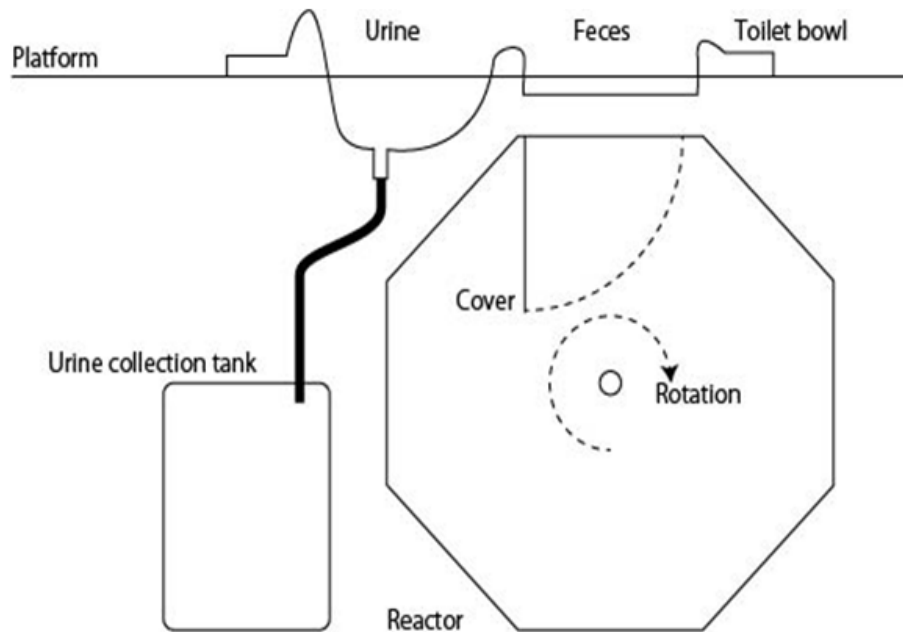

Figure 4. 1. Schematic diagram of composting toilet with continuously supply of feces

#### 4.2.2. Storage treatment set up

Storage treatment was performed in a short time (2 months) in uncontrolled conditions, fresh compost from household composting toilet was stored for short time in uncontrolled conditions.

#### 4.2.3. Physico-chemical parameters before and after storage treatments

Physico-chemical analyses before (fresh compost) and after storage (stored compost) were conducted as follows: temperatures at different depths (top, middle and bottom) were recorded using a portable multi-logger ZR-RX45 (manufactured by OMRON). The pH was measured in 1:5 water extract with a Hanna Digital Compo Meter (HI991405, Hanna, UK). Free ammonium concentration was determined using micro-kjeldahl distillation method. Moisture content was determined through the weight loss at 105°C by the procedures established in the Standard methods (Eaton et al, 2005).

#### 4.2.4. Microbiological analysis of fresh and stored compost

Preparation of compost for hygienic analysis was performed as recommended by Sikora et al. (1983). A portion (50g) of the compost sample was dispersed in 950 mL of sterile water. They were then submitted to a mechanical shaking for 2h. On the resulting solid-liquid suspension, and a 10-fold dilution series was performed in maximum recovery diluents and used for bacteria enumeration.

The total mesophilic bacteria were determined by the dilution plate method as described by Hassen et al. (2001). Fecal coliform and enterococci were cultured following a modification

of method 9215 A in Standard Methods for the Examination of Water and Wastewater (APHA, 1998). Relevant dilutions were spread on plates in duplicate on the following selective media: chromocult coliform agar ES (Difco, France) was used for fecal coliform, and Slanetz Bartley agar (Difco, France) was used for Enterococci. Spores of sulphite-reducing clostridia (SSRC) were counted by the procedure described by Bufton (1959). The concentration of *Salmonella* spp. was determined by most probable number (MPN) method using a five tube set-up according to 9260 B Standard Methods (APHA, 1998). Buffered peptone water was used as pre-enrichment solution and Semisolid Rappaport–Vassiliadis (MSRV) was used for each dilution for the MPN analysis. Positive results were confirmed with xylose lysine desoxycholate agar (XLD) plates (Oxoid, France) containing 0.15% sodium-novobiocin.

For parasitological analysis, 50 g of compost sample were homogenized with 950 mL of 0.1% Tween 80 for 1 min using a blender and screened through 4 layers of folded gauze compress. The filtrate was collected in round bottom flasks and allowed to settle for 3 hours and submitted to analysis. Helminth eggs were determined by the US EPA protocol (1999) modified by Schwartzbrod (2003) with a modified density of zinc sulfate saline solution. The enumeration of protozoan cysts was performed by the method of Gaspard and Schwartzbrod (1993), with a combination of sedimentation and filtration using a solution of sodium acetate formaldehyde. The number of eggs or cysts per gram of compost was calculated using the relevant percentage water content.

#### **4.2.5. Statistical analysis**

Some parameters were analyzed using factorial analysis of variance (ANOVA) using the StatView software version 5.0 (SAS Institute Inc., Cary, NC, USA) at least significant differences test at  $p < 0.05$ .

### **4.3. RESULTS AND DISCUSSION**

#### **4.3.1. Physico-chemical property change of compost during storage**

The physico-chemical property change of compost during storage was presented in Table 4.1. The pH in compost, decrease from 7.64 to 7.48 during the storage. The concentration of free ammonium in compost, decreased slightly from 193 to 165 mg/kg. The reduction of free ammonium concentration is probable due to its conversion and its volatilization as ammonia. In the other hand, the loss of this ammoniacal nitrogen by storage is responsible of the pH reduction. The moisture content in the compost was 22.4 % before storage and decreased to 14.5 % after the storage. This reduction corresponding to a loss of water in compost would indicate a drying effect during storage. For all physico-chemical parameters analyzed, there was no significant change of values during storage treatment, indicating that these parameters didn't have enough effects on microorganisms' inactivation.

Factors that mainly influenced the survival of microorganisms in a biosolid are represented by pH, free ammonia concentration, moisture content and duration of treatment which may

enhance microorganism's inactivation (Turner, 2002). In this study, there was no significant change of physicochemical parameters during storage time. Thus, this would indicate that the change of physicochemical parameters didn't have effects on microorganisms' inactivation. Therefore time-storage was the main process responsible for microorganisms decay during storage.

Table 4. 1. Physico-chemical property change during compost storage

Parameters	Fresh compost	Stored compost
pH	7.64 (0.06)*	7.48 (0.05)*
Free ammonium (mg/l)	193 (7.01)	165 (6.8)
Moisture content (%)	26.4 (0.91)	14.5 (0.7)

\*Data in parentheses are Standard deviations

#### 4.3.2. Hygienic quality of fresh and stored composts

Microbiological analysis of fresh and stored composts presented in Table 4.2, showed that both fresh and stored composts contained mesophilic bacteria, indicator bacteria (fecal coliform, enterococci and SSRC), pathogenic bacteria (*Salmonella sp*) and intestinal parasites (helminthes eggs and protozoan cysts). The hygienic quality of fresh and stored composts was appreciated by comparing the microbial level to the limit set by WHO (2006) and other authors reference about fecal matter (compost in our case).

Table 4. 2. Microbiological analysis fresh and stored composts

Parameters	Fresh compost	Stored compost
Total mesophilic bacteria (UFC/g)	$5.46 \times 10^7$	$2.23 \times 10^6$
Fecal coliform (UFC/g)	$5.2 \times 10^5$	$2.6 \times 10^4$
<i>E. coli</i> (UFC/g)	$7.8 \times 10^2$	$2.17 \times 10^1$
Enterococci (UFC/g)	$8.4 \times 10^3$	$5.25 \times 10^2$
Spores of SRC (UFC/g)	$6.3 \times 10^3$	$4.67 \times 10^2$
<i>Salmonella</i> spp. (MPN/g)	13	0
Total helminthes eggs (eggs/g)	21	2
Total protozoan cysts (cysts/g)	123	74

The population of total mesophilic bacteria count in fresh and stored composts was  $5.46 \times 10^7$  and  $2.23 \times 10^6$  (UFC/g), respectively. The mesophilic bacteria present in the fresh and stored composts are those responsible for organic material's biodegradation during composting process in the composting toilet.

Fecal coliforms were detected in the fresh and stored composts at the level of  $5.2 \times 10^5$  and  $2.6 \times 10^4$  CFU/g, respectively. Fecal coliforms limit values for sanitized compost have been



proposed as  $5 \times 10^2$  cfu/g by Zucconi and de Bertoldi (1987). Therefore, fecal coliforms level of both composts is out of the upper set limit for fecal coliforms. Enterococci were present in the fresh and stored composts at level of  $8.4 \times 10^3$  to  $5.25 \times 10^2$  CFU/g. Zucconi and de Bertoldi (1987) have proposed a limit values for Enterococci in sanitized compost as  $5 \times 10^3$  cfu/g. This indicated that both composts exceeded the upper limit set for Enterococci. Spores of SRC were detected in fresh and stored composts at levels higher than  $6.3 \times 10^3$  and  $4.67 \times 10^3$  cfu/g. There is no set limit for SSRC in compost, because high populations of SSRC are common in composted materials.

Only the fresh compost was contaminated by *Salmonella* with number of 13 MPN/g. All compost regulations required that *Salmonella* must be absent in compost intended for land application (Zucconi and de Bertoldi, 1987). Helminths eggs were detected in the fresh and stored composts with numbers of 21 and 2 eggs/g, respectively. Protozoan cysts were detected in the fresh and stored composts with numbers of 123 and 74 cysts/g, respectively. WHO (2006) guidelines required an absence of all pathogens, therefore *Salmonella*, helminthes eggs and protozoan cysts detected in fresh and stored compost should be absent. Very few data are instead present in the literature in relation to the other organisms apart from *Salmonella* (Skanavis and Yanko 1994).

The results obtained in this study about presence and level of microorganisms detected, were in good agreement with those obtained from previous studies (Bigot et al. 1997; Christensen et al. 2000).

#### **4.3.3. Health implications of microbial population in fresh and stored composts**

The microbial activity responsible for organic material's biodegradation during composting is mainly due to mesophilic bacteria community. The number of mesophilic bacteria measured in this work is similar to those found by Lasaridi et al. (2006) and Hassen et al., (2001) equivalent to those normally found in fertile soils. The mesophilic bacteria did not represent an health risk for compost reuse.

Fecal coliforms bacteria are often used as indicator of overall sanitary quality of composts. According to international literature, fecal coliforms do not appear significant indicators of the hygienic quality of compost because of their ubiquity in the environment (Dumonet et al. 1999, Principi et al. 2003). Among the bacterial indicators of fecal pollution, the role of *E. coli* must be considered because this bacterium has a good correlation with the presence of other enteric bacteria with the same characteristics and sometime pathogenic bacteria.

In the same manner, the Enterococci, with their known higher resistance to physico-chemical treatments and their close connection to the final gut tract of warm-blooded animals, could be a valid faecal indicator group (Yanko 1988, Gibbs et al. 1994). The population of enterococci is another indicator of product sanitization during composting but is directly related to the high temperatures attained during composting. High populations of SSRC are common in composted materials, as these bacteria survive to high temperatures of the composting process through their transformation into a very resistant form, the endospore. The presence of these

microorganisms in fresh and stored composts may be attributed to insufficient heat required for pathogens destruction during the active phase of composting process (Vuorinen et al., 2003).

The presence of *Salmonella* is considered as a major problem of the hygienic quality of compost (Hassen et al., 2001). In stabilized compost the detection of *Salmonella*, a human frank pathogen, is very important in order to evaluate the sanitary quality of stable compost and to limit the health risk. The presence of this pathogen in finished composts leads to the assumption of shortages in the composting process (Sidhu et al., 2001). *Salmonella* is known to survive for long periods (up to 250 days) in soil amended with compost containing *Salmonella* as fertilizer (Jones, 1985). Turpin et al. (1993) reported that *Salmonella* may persist in soil for longer period but in a viable non cultivable state and cannot be detected by traditional technique.

Helminths eggs have a low hygienic and sanitary significance for humans even if their presence could have some agronomic implications. Among helminthes eggs, *A. lumbricoides* eggs have been shown to have the longest survival time of most indicator pathogens and are used to predict pathogen inactivation in fecal material (Schonning and Stenström, 2004).

Among, protozoan cysts, *Entamoeba histolytica* was used to monitor the fate of protozoan cysts because *E. histolytica* is pathogenic and is an important intestinal infection protozoan in agriculture resource-poor settings (Pham Duc et al., 2011). Even protozoan parasites have an extremely low infective dose, a single protozoan cyst has been observed to cause infection (US EPA, 1999); so survival of even a single cyst is a matter of concern. However, WHO (2006) required an absence of parasites in fecal material before reuse in agriculture.

Due to their fecal origin, composts usually contained variable amounts of enteric pathogens (Pepper et al., 2006). Although the hygiene risk in organic waste types may be variable, in order to secure good hygienic quality, compost has to be treated effectively, either by heating or chemical treatment with stabilizing additives such as lime or urea (Albihn and Vinnera' s, 2007).

#### **4.4. CONCLUSION**

This study was investigated to evaluate the sanitization effectiveness of storage treatment of compost as post-treatment for a short time. The microbiology analysis of fresh and stored composts showed that, both composts contained indicator bacteria (fecal coliforms, enterococci, spores of sulphite-reducing clostridia), pathogenic bacteria (*Salmonella*) and intestinal parasites (helminthes eggs and protozoan cysts), at levels above suggested limits for compost quality. There was no significant difference of the microbial level in fresh and stored composts exanimated, thus the storage period tested resulted in slow reduction of microorganisms for compost quick sanitizing. However the microbial level in fresh and stored composts from a composting toilet was known and their health implications suggested further sanitizing treatments.

#### 4.5. REFERENCES

- Agnew J. M. and Leonard J. J. (2003) The physical properties of compost. *Compost Science and Utilization*, 11(3), 238-264.
- Albihn A. and Vinnerås B. (2007) Biosecurity and arable use of manure and biowaste treatment alternatives. *Livestock Science*, 112, 232–239.
- Anand, C. and Apul, D. S. (2011) Economic and environmental analysis of standard, high efficiency, rainwater flushed, and composting toilets. *Journal of Environmental Management*, 92(3), 419-428.
- APHA (1998) Standard methods for the examination of water and wastewater. 20<sup>th</sup> ed. United Book Press, Inc., Baltimore, MD.
- Gibbs, R. A., Hu, C. J., Ho, G. E., and Unkovich, I. (1997) Regrowth of faecal coliforms and salmonellae in stored biosolids and soil amended with biosolids. *Water Science and Technology*, 35(11), 269-275.
- Mehl J., Kaiser J., Hurtado D., Gibson D., Izurieta R. and Mihelcic J. (2011) Pathogen destruction and solids decomposition in composting latrines: study of fundamental mechanisms and user operation in rural Panama. *Journal of Water and Health*, 9, 187-199.
- Mnkeni, P. N. S., and Austin, L. M. (2009) Fertiliser value of human manure from pilot urine-diversion toilets. *Water SA*, 35(1), 133-138.
- Paluszak, Z., Skowron, K., Sypuła, M., & Skowron, K. J. (2012) Microbiological Evaluation of the Effectiveness of Sewage Sludge Sanitization with Solar Drying Technology. *International Journal of Photoenergy*, 2012.
- Sobczyk, R. “Gospodarka komunalnymi osadami ‘sciekowymi teoria a praktyka,” (2007) *Proceedings of the 6<sup>th</sup> Konferencja Naukowo-Techniczna Woda-Człowiek-S’rodowisko*, Lichen’, Poland, [In Polish].
- Vinnerås, B., Holmqvist, A., Bagge, E., Albihn, A., Jönsson, H., (2003) Potential of disinfection of separated faecal matter by urea and by peracetic acid for hygienic nutrient recycling. *Bioresource Technology*, 89, 155–161.
- Vinnerås, B., Nordin, A., Ottoson, J., Berggren, I., Albihn, A., Bagge, E., & Sahlström, L. (2004) Removal of Salmonella contamination before using plant nutrients from household waste and wastewater in agriculture. DIAS report, 107.
- Vinnerås, B., Palmquist, H., Balmer, P., Jönsson, H., (2006) The composition of household wastewater and biodegradable solid waste – proposal for new norms for the flow of nutrients and heavy metals. *Urban Water Journal*, 3, 3–11.

Washington State Department of Health (WSDOH), (2007) Water conserving on-site wastewater treatment systems. Recommended Standards and Guidance for Performance, Application, Design, and Operation & Maintenance. DOH, Publication #337–016.

WHO (2006) Guidelines for the safe use of wastewater, excreta and greywater, Volume 4: Excreta and greywater use in agriculture, World Health Organisation, Geneva, Switzerland.

WHO/UNICEF (2013) Joint Monitoring Program for Water Supply and Sanitizing. [<http://www.wssinfo.org/>]

## Chapter 5

### POST-TREATMENT BY SOLAR HEATING FOR SANITIZING COMPOST FROM COMPOSTING TOILET

#### 5.1. INTRODUCTION

Serving over 3 billion people, mainly in low- and middle-income countries, on-site sanitation is still the main solution for the majority of the world's population for sanitizing human excreta (WHO/UNICEF, 2013). However, excreta management remains a big issue in these countries where some part of the fecal matter is used without treatment as fertilizer (Jiménez et al., 2009). Indeed, toilet waste fractions contain a major proportion of nutrients from households (Vinnerås et al., 2003) which are associated with a high risk of pathogen content and have to be disinfected before use as fertilizer or soil conditioner. Producing a safe fertilizer from human feces enables to break the fecal-oral transmission route via emission to the recipient water and contaminated food. For avoiding this transmission along the food chain, contamination has to be broken as early as possible.

Common technologies applied in sanitizing for treatment of feces include the use of different types of latrines, septic tanks, and dry or composting toilets (Mnkeni and Austin, 2009). The most common treatment is composting, where the main inactivation of pathogens is due to increased temperature (WHO, 2006). However, in most cases, the temperature of composting toilet in developing countries, do not greatly increase to destroy all pathogens (Sossou et al., 2014a). Accordingly, the practice of adding inert materials like ash and soil in dry toilets may hamper heat generation in the compost (Niwagaba et al., 2009). Even with heat generation, maintenance strategies, such as turning the compost during high temperature periods, are necessary to ensure inactivation of the entire volume of the matrix (Mote et al., 1988). Low-temperature degradation of fecal matter, i.e. storage, requires a treatment time exceeding a year (WHO, 2006) and even with that the product cannot be considered as pathogen-free.

One of the most reliable methods for sanitizing compost is heating. The unconventional, low-temperature technology of solar heating of fecal material is a prospect from the economic and ecological point of view (Paluszak et al., 2012). Due to sanitary and epidemiological reasons, it is necessary to establish microbiological methods which will allow constant monitoring of compost sanitization effectiveness in solar heating process. To reach high and efficient temperatures for the inactivation of pathogens in full compost, heating has to be accumulated and preserved for a long time to achieve appropriate disinfection (Vinnerås, 2007). Considering the idea of using the cheapest and available energy for fast thermal sanitizing, solar energy is an alternative to increase heating efficiency (Rendall, 2012). Using a solar box, a simple and low-cost heating system available locally in Burkina Faso, compost can be heated at a sufficient temperature to destroy most of the pathogens in a few hours without burning the organic matter. Solar box can concentrate sunlight at high intensity and then be used for inactivating pathogens in compost.

Several studies report the sanitizing of human feces (Vinnerås et al., 2003), manure (Ghaly and MacDonald, 2012) and sludge (Sypuła et al., 2013) by thermal treatment, but the effectiveness of these systems on compost has not been studied yet. The lack of information about solar heating in tropical conditions indicates the necessity for further studies on the processes and questions the promotion of sanitation in a safe way. Investigation on the possibility of applying a new approach in sanitizing fecal material could shorten the storage time and minimize handling of compost. Inactivation rate or the degree of decay can be used to assess and compare the quantitative effectiveness of a treatment process on pathogen destruction (Lang and Smith, 2008). This study aimed to estimate the sanitization effectiveness of solar heating of compost from composting toilet by comparing direct sunlight and solar box heating.

## **5.2. MATERIAL AND METHODS**

### **5.2.1. Compost collection**

Compost used for the experiments was collected from a urine-diverting composting toilet prototype installed in a pilot household located in Ouagadougou, the capital city of Burkina Faso. This toilet coupled with an aerobic composting reactor was used by 8-10 persons with a total of 6 to 8 kg of compost produced for approximately 2 months. The matrix used as bulking agent was sawdust and there was no chemical source addition (ash or lime) as alkaline treatment. Compost samples were collected and stored at 4°C.

### **5.2.2. Collection of microorganisms and suspension preparation**

Compost samples were inoculated by selected indicator bacteria and parasite eggs in order to assess the entire inactivation process. The bacterial strains, *Escherichia coli* ATCC 25922 and *Enterococcus faecalis* ATCC 29212, used in this study were purchased from the American Type Culture Collection (ATCC, USA). For suspension preparation, each bacteria, *E. coli* and *E. faecalis*, were cultured in a growth medium Nutrient Broth (Difco, France) and incubated in a shaking water bath at 37°C overnight. The bacterial suspensions were used as a source of inoculums. The parasites used were *Ascaris lumbricoides* eggs which were extracted from human feces collected from patients at a hospital in Ouagadougou, Burkina Faso. According to the method of Collick et al. (2007), the feces collected were washed through a series of sieves ranging from 425 to 38 µm. Eggs were finally collected on the 38-µm sieve. The eggs were stored in a 4°C refrigerator in reverse osmosis water and 10% formaldehyde to prevent mold growth. Upon use, a portion of the egg solution was collected as a source of inoculums.

For compost sample inoculation, an adequate aliquot of *E. coli* (0.3 mL about  $10^7$  CFU/mL), *E. faecalis* (0.3mL about  $10^7$  CFU/mL) and *Ascaris* eggs (1 mL about  $10^3$  eggs) was added to 1000 g of autoclaved (121°C) compost. The concentrations of microorganisms added were normal concentrations found generally in feces in the area of this study. Before subjecting to solar heating, the moisture content of compost sample was adjusted to 20% (w/w) with sterilized deionized water.

### 5.2.3. Solar heat treatment set up

The solar heating experiment was carried out at 2iE University campus located in Ouagadougou City, latitude  $12^{\circ}17.5$  and longitude  $1^{\circ}7'$ . Compost samples were subjected to heating by exposing them directly to the sun and placing in a solar box, resulting in two platforms of treatment. As control, the same amount of compost was kept at  $4^{\circ}\text{C}$  in laboratory throughout the experimental period. In each treatment platform, the compost was spread out in a conical shape of 40-cm diameter and 30-cm height.

For direct sun exposure, the platform was made up of wood with a size of 85-cm length x 40-cm width. The solar box used (Fig. 1) had a size of 85-cm length  $\times$  40-cm width  $\times$  30-cm height at the front cover and  $\times$  40-cm height at the back cover. It can provide temperatures for heating by combining the technique of solar concentration rays and greenhouse effect. The box had an absorbing plate surface of  $0.54\text{ m}^2$  and a thermal conductivity of  $80\text{ Wm}^{-1}\text{K}^{-1}$ . The insulating material was made with wood, plywood, kapok wool, cotton wool and thick reflective paper. The solar box was provided by the Laboratory of Solar Energy and Energy Savings of the same university.

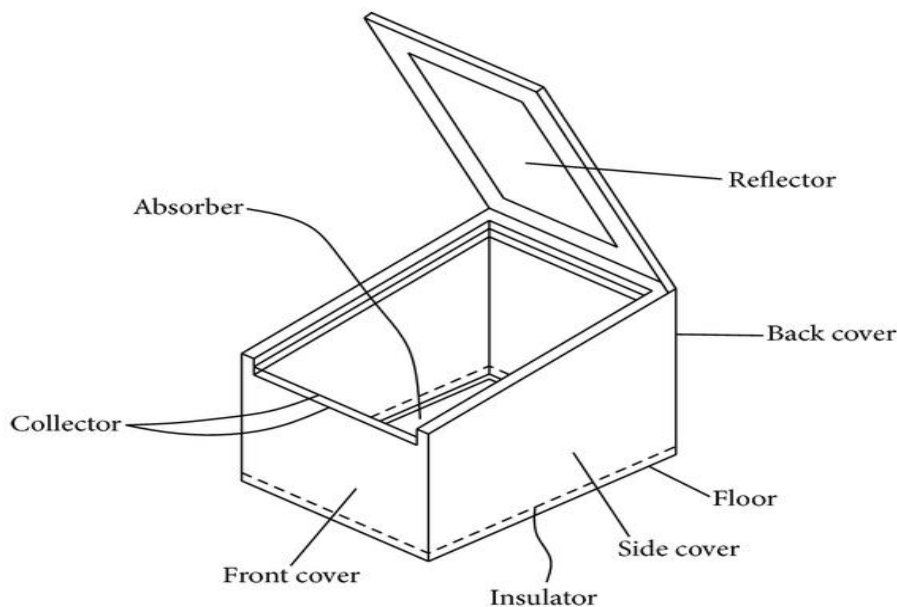

Figure 5. 1. Solar box used

### 5.2.4. Sampling

The compost samples subject to heating and the control compost were sampled at every hour interval during 5 hours. The top layer of compost was removed with a hand trowel; one scoop of compost was collected and placed in a sterilized bucket. The procedure was repeated for a total of three grab samples for each sampling depth: top, middle and bottom. The three grab samples were mixed thoroughly in the bucket with the hand trowel and a subset of the mixed sample was transferred to a sterilized bottle. The bottle was sealed and placed in an insulated

cooler with ice. The composite sample (30 g) was assayed for microbiological and physicochemical analyses.

### **5.2.5. Microbiological analysis**

For bacterial extraction, a 3% (w/v) beef extraction solution was used. Ten grams of compost sample was added to a 90-ml volume of extracted solution and agitated for 3 minutes to extract bacteria. After adequate dilution (7 fold) with phosphate buffer, each extract was inoculated by double-layer method in Chromocult coliform agar ES (Difco, France) for *E. coli* and Slanetz-Bartley agar (Difco, France) for *E. faecalis*. These inoculated media were incubated at 37°C for 24 h for *E. coli* colony count and at 37°C for 48 h for *E. faecalis* colony count. The detection limits of bacteria were 10 CFU/g and the concentration of bacterial count was expressed in CFU/g of dry compost.

For parasite analysis, 10 g of compost sample was homogenized with 90 mL of 0.1% Tween 80 for 1 min using a blender and screened through 4 layers of folded gauze compress. The filtrate was collected in round-bottom flasks and allowed to settle for 3 hours. The number of *Ascaris* eggs was determined by the concentration method followed by a direct count under optical microscope (B-350, OPTIKA, Italy), described by Sossou et al. (2014a). The viability of *Ascaris* eggs was assessed both by morphological analysis for integrity (normal cellular structure) and staining through dye exclusion method using Safranin O. If the dye had penetrated into the eggs, they were counted as nonviable. The detection limits of *Ascaris* eggs were one egg/g and the number of *Ascaris* egg count was expressed as number of eggs/1000 g of dry compost.

### **5.2.6. Physico-chemical analysis**

Compost temperatures at different depths: top, middle and bottom, were recorded using a portable multi-logger ZR-RX45 (OMRON, Japan) at every hour interval from 11:00 a.m. to 4:00 p.m local time. The pH was measured in 1:5 water extract with a Hanna Digital Compo Meter (HI991405, Hanna, UK). Free ammonium concentration was determined using micro-Kjeldahl distillation method. Moisture and ash content were determined through the weight loss at 105 and 550°C, respectively, by the procedures established in the standard methods (Eaton et al, 2005).

### **5.2.7. Climatic conditions monitoring**

The solar heating experiment was carried out in September during the summer period and there was no rainfall throughout the experimental day. Meteorological data of the experimental day, such as air temperature, insolation and humidity, were taken from Burkina Faso Meteorological Station.

### **5.2.8. Data analysis**

During the solar heating experiment, temperature and other environmental factors affecting microbial inactivation were not constant. Therefore, the Geeraerd and Van Impe Inactivation



Model Fitting Tool (GInaFiT) was used for testing microbial inactivation models best fitting our data (Geeraerd et al., 2005). The best-fitting models were the log-linear regression for *E. coli* and *E. faecalis*, and the log-linear regression plus shoulder for *Ascaris* eggs. All models were run for each inactivation curve and the values of the root-mean-square error (RMSE) were compared. The RMSE is considered to be the simplest and most informative measure of goodness-of-fit for linear and nonlinear models (Geeraerd et al., 2005). The model with the smallest RSME was considered the best fit for the respective inactivation curve. When the magnitude of RMSE was much smaller than the experimental precision, the model was considered to over-fit the data and a simpler model was chosen. If two models had the same or very similar RMSE values, the simpler model was considered to fit best. The maximum inactivation rate constant  $k_{max}$  ( $h^{-1}$ ) and the decimal decay T90 values (time to inactivate 90% of the population) were calculated using the best fitting model in GInaFiT. The kinetics destruction by log-linear regression and log-linear regression plus shoulder were expressed respectively as follows:

$$N(t) = N(0).e^{-k_{max}.t} \quad \text{(Equation 5. 1.)}$$

$$N(t) = N(0).e^{-k_{max}.t} \cdot \frac{e^{k_{max}.Sl}}{1+(e^{k_{max}.Sl}-1).e^{-k_{max}.t}} \quad \text{(Equation 5. 2.)}$$

where  $N(t)$  and  $N(0)$  expressed in CFU or number of eggs/g of dry compost are the concentrations of microorganism in compost at time  $t$  and 0, respectively; and  $t$  is the reaction time (h). The parameter used for the estimation by GInaFiT was  $Sl$  (shoulder length i.e. the length of the lag phase) (h), which represents the degrees of freedom. The  $k_{max}$  values and standard deviation were calculated directly by GInaFiT program.

All results were expressed as the mean values of three independent experiments. Log10 transformed microorganisms' counts were subjected to one-way and two-way analysis of variance (ANOVA) to compare the effects of the type of treatments (control, sun and solar box) and the duration time of treatment. The one-way ANOVA was also applied on physicochemical parameters of compost before and after treatment. Treatment means were compared with the least significant differences test at  $p < 0.05$ . These statistical analyses were performed using StatView Software version 5.0 (SAS Institute Inc., Cary, NC, USA).

## 5.3. RESULTS AND DISCUSSION

### 5.3.1. Parameters monitoring during solar heating

The sanitization effectiveness of compost by solar heating was closely associated with weather conditions. During the day of the experiment, from 11:00 a.m. to 4:00 p.m., the average daily level of solar radiation was  $598.4 \text{ W.m}^{-2}$ , and the maximum radiation recorded reached the value of  $610 \text{ W.m}^{-2}$ . The relative humidity was dependent on the air humidity and showed considerable fluctuations; the lowest value was 32%, the highest was 64%, and the average was 48%.

Figure 2 and 3 showed the change of ambient temperature and temperature at different depths of compost pile during direct sunlight and solar box heating. The results showed that, the ambient temperature varied from 35.5°C to 44.5°C, with the average value of 38.4°C. During direct sunlight heating, the recorded temperatures at each depth of compost pile reached their maximum after 3 hours and were 47, 44, and 41°C at the top, middle, and bottom, respectively. On the other hand, during solar box heating, the recorded temperatures at each depth reached their maximum after 3 hours and were 76, 72, and 70°C at the top, middle, and bottom, respectively. As expected, the increase of compost temperatures during solar heating was significantly correlated with the duration of heating process. The solar box heating significantly increased the temperatures at each depth of the compost pile than direct sunlight heating. Such results highlighted that rapid inactivation temperatures above 55°C could be reached only with the solar box since direct sunlight heating never reach this minimum temperature. Furthermore, in the solar box, the temperature profiles at different depths showed similar values indicating a uniform temperature distribution in the compost pile during heating. The recorded temperatures in the compost control were slightly below those of ambient temperature.

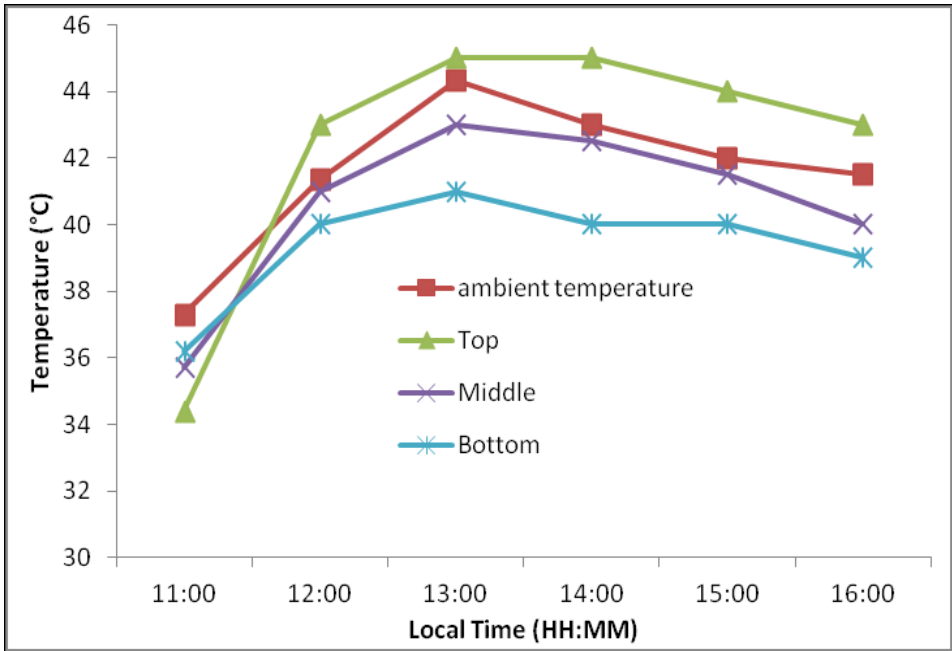

Figure 5. 2. Ambient temperature and temperature in compost during sunlight heating

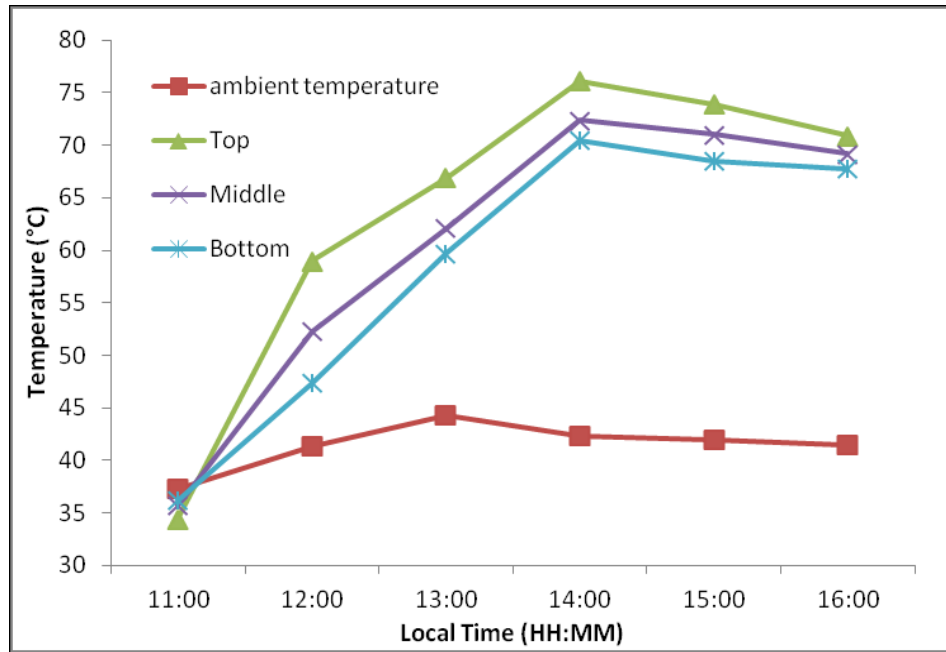

Figure 5. 3. Ambient temperature and temperature in compost during solar box heating

### 5.3.2. Physico-chemical property change of compost during solar heating

The physicochemical property change of compost during heating is presented in Table 1. The pH in compost decrease from 7.64 to 7.49 for direct sunlight heating and to 7.43 for solar box heating. The concentration of free ammonium in compost decreased slightly from 190 to 173 mg/kg for sun heating and to 161 for solar box heating. The reduction of free ammonium concentration is probably due to its conversion and its volatilization as ammonia. On the other hand, the loss of this ammoniacal nitrogen by heating temperature is responsible for the pH reduction. The moisture content in the compost was 20% before heating but it decreased to 12.97% after direct sunlight heating and to 10.02% after solar box heating. This reduction corresponding to a loss of water in compost during heating would indicate a drying effect during solar heating. The ash content showed minimal losses of 1.86% and 2.19% during direct sunlight heating and solar box, respectively. For all physicochemical parameters analyzed, there was no significant change in values during heating indicating that these parameters did not have enough effects on microorganisms' inactivation.

Table 5. 1. Physico-chemical property change during compost solar heating

Parameters	Before treatment	After treatment		
		Control	Solar sun	Solar box
pH	7.64 (0.05)*	7.61 (0.23)	7.49 (0.02)	7.43 (0.72)
Free ammonium (mg/l)	190 (7.01)	189 (6.3)	173 (5.9)	161 (5.4)
Moisture content (%)	20 (0.91)	19.59 (0.84)	12.97 (0.69)	10.02 (0.63)
Ash content (%)	12 (0.08)	11.83 (0.07)	10.14 (0.06)	9.81 (0.05)

\*Data in parentheses are Standard deviations

### 5.3.3. Change of indicator microorganisms during solar heating

The change of the number of *E. coli*, *E. faecalis* and *Ascaris* eggs during solar heating are presented in figures 4, 5 and 6, respectively. The results showed that solar heating significantly reduced the number of microorganisms tested.

The change of *E. coli* and *E. faecalis* population in compost showed a linear curve of regression. After 5 hours of heating, the number of *E. coli* decreased to an average of about 1.6 log reduction for direct sunlight heating and about 3.2 log reduction for solar box heating. At the same time, the number of *E. faecalis* isolated from compost decreased to an average of about 0.8 log reduction for direct sunlight heating, and by about 1.6 log reduction for solar box heating. A linear regression analysis indicated that there was a significant decay in the log numbers of *E. coli* and *E. faecalis* during solar heating and in relation with exposure duration. The inactivation curves for *Ascaris* eggs showed two phases: a lag phase as an initial phase followed by a rapid decrease corresponding to shoulder and log-linear decay. The reduction in the *Ascaris* population during solar heating was about 0.2 log reduction with direct sunlight heating and about 0.8 log reduction with solar box heating. The nonlinear regression of *Ascaris* eggs indicated that there was a significant decay in the log numbers during solar heating and in relation with exposure duration. For all microorganisms tested, the number detected in treated composts declined more rapidly in compost heated by solar box than that of direct sunlight.

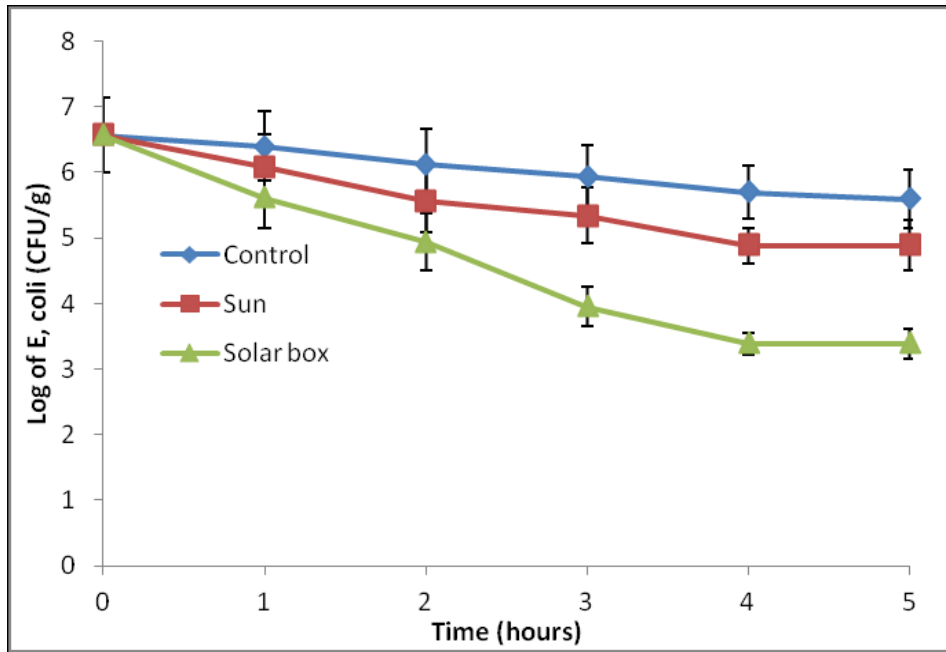

Figure 5. 4. Change of *E. coli* during solar heating

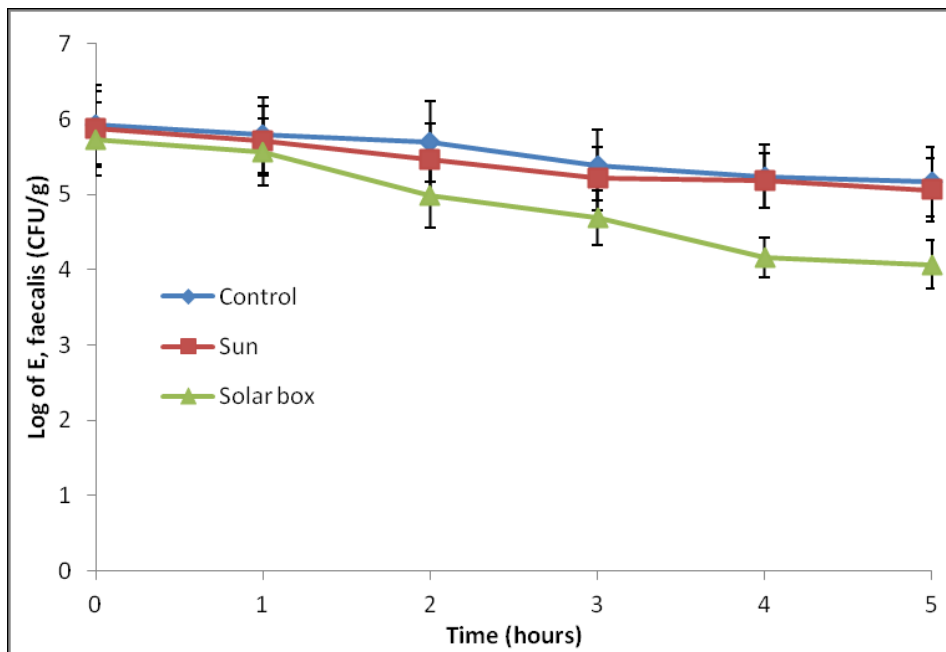

Figure 5. 5. Change of *E. faecalis* during solar heating

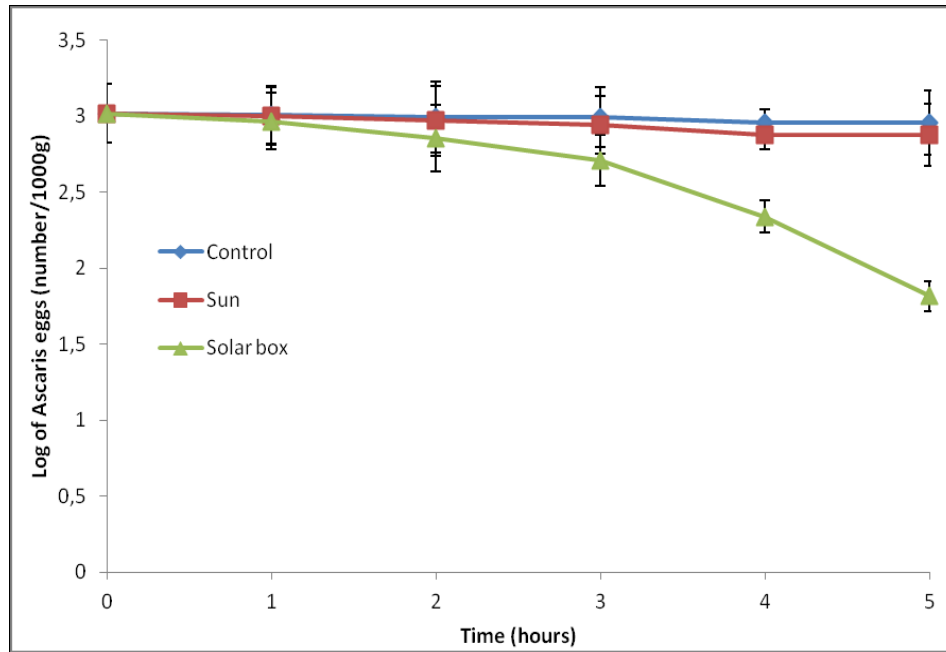

Figure 5. 6. Change of *Ascaris* eggs during solar heating

#### 5.3.4. Inactivation rate and decay of microorganisms during solar heating

The estimated  $k_{max}$  and T90 of microorganisms determined during solar heating are presented in Table 2. The  $k_{max}$  of *E. coli*, *E. faecalis* and *Ascaris* eggs in compost heated by direct sunlight were 0.82, 0.39 and 0.34 h<sup>-1</sup>, respectively while in compost heated by solar box were 1.55, 0.84 and 0.73 h<sup>-1</sup>, respectively. This indicated that the inactivation rate was slower in compost heated by direct sunlight but fast in compost heated by solar box. The T90 values of *E. coli*, *E. faecalis* and *Ascaris* eggs in compost heated by direct sunlight were 1.22, 2.56 and 2.94 hours, respectively while in compost heated by solar box were 0.65, 1.19 and 1.37 hours, respectively. This revealed that the thermal decimal decay occurred rapidly in solar box while it was prolonged with the sun. The effective significant difference of  $k_{max}$  and T90 values was observed between compost heated by solar box and that of direct sunlight. For all microorganisms tested,  $k_{max}$  was reduced while T90 values were prolonged with temperature decrease. These results demonstrated the positive effects of solar heating on microbial inactivation

Table 5. 2. Estimated maximum inactivation rate constant ( $k_{max}$ ), decimal decay rate (T90) and root-mean-square error (RMSE) of regression lines for microorganisms

Treatment	<i>E. coli</i>			<i>E. faecalis</i>			<i>Ascaris</i> eggs		
	$k_{max}$ (h <sup>-1</sup> )	T90 (h)	RMSE	$k_{max}$ (h <sup>-1</sup> )	T90 (h)	RMSE	$k_{max}$ (h <sup>-1</sup> )	T90 (h)	RMSE
Control	0.47 <sup>a*</sup>	2.13 <sup>a</sup>	0.0494	0.38 <sup>a</sup>	2.63 <sup>a</sup>	0.0708	0.26 <sup>a</sup>	3.85 <sup>a</sup>	0.0013
Direct sunlight	0.82 <sup>b</sup>	1.22 <sup>b</sup>	0.1500	0.39 <sup>a</sup>	2.56 <sup>a</sup>	0.0830	0.34 <sup>a</sup>	2.94 <sup>a</sup>	0.0027

Solar box	1.55 <sup>c</sup>	0.65 <sup>c</sup>	0.3318	0.84 <sup>b</sup>	1.19 <sup>b</sup>	0.1252	0.73 <sup>b</sup>	1.37 <sup>b</sup>	0.006
-----------	-------------------	-------------------	--------	-------------------	-------------------	--------	-------------------	-------------------	-------

\* For each parameter, values followed by different alphabetical letter are significantly different for  $p < 0.05$

### 5.3.5. Discussion

The experimental protocol described in this study was designed to measure the instantaneous effects of different time-temperature exposure to solar heating on the survival of microorganisms. The results of temperature increase during the experiment showed that the tested temperature conditions were categorized into mesophilic ( $>30^{\circ}\text{C}$ ) and pasteurization ( $>70^{\circ}\text{C}$ ) for direct sunlight heating and solar box heating, respectively (Lang and Smith, 2008). Furthermore, recorded temperatures in the compost placed in the solar box showed similar values at different depths. This indicated a uniform temperature distribution in the compost pile during solar box heating. The elevated temperature during direct sunlight and solar box heating should show an effect on pathogen destruction. Indeed, solar heating can effectively destroy pathogens in fecal material when raising the temperature (Ozdemir et al., 2013).

During compost heating with direct sunlight at mesophilic conditions for 5 hours, only a slight reduction (1.1-2.1 log reduction) of microorganisms was observed, indicating a low sanitizing effect. This low sanitization effectiveness of direct sunlight heating was confirmed by the results obtained by Mathioudakis et al. (2009). Similar to these results, Bux et al., (2001) and Ögleni and Özdemir (2010), have obtained a low degree of elimination of fecal pathogens, not exceeding 1 log reduction with direct sunlight heating. The optimum cardinal temperature for growth and survival of enteric organisms is in the range of  $30\text{-}40^{\circ}\text{C}$  (Lang and Smith, 2008). Therefore, mesophilic temperatures could not exert a specific thermal stress on the decay of microorganisms. During compost heating with solar box at pasteurization conditions for 5 hours, a significant reduction (2.1-3.1 log reduction) of microorganisms was observed. In similar conditions (above  $55^{\circ}\text{C}$ ), Aitken et al. (2005) and Popat et al. (2010) reported  $> 3$  log reduction of pathogens. Pasteurization temperatures ranging from  $65$  to  $80^{\circ}\text{C}$  are very effective in pathogen inactivation (Nosrati et al., 2006).

As expected for each microorganism tested (*E. coli*, *E. faecalis* and *Ascaris* eggs), the maximum inactivation rate constant was significantly low (0.82; 0.39;  $0.34\text{ h}^{-1}$ , respectively) during direct sunlight heating but significantly high (1.55; 0.84;  $0.73\text{ h}^{-1}$ , respectively) during solar box heating. So, the pasteurization conditions ( $>70^{\circ}\text{C}$ ) by solar box heating showed a rapid inactivation of microorganisms than the mesophilic conditions ( $>30^{\circ}\text{C}$ ) by direct sunlight heating. The inactivation of microorganism with increasing temperature and treatment duration are well defined. A thermophilic temperature higher than  $55^{\circ}\text{C}$  is sufficient to destroy all enteric organisms, whereas mesophilic conditions extend treatment duration (Lang and Smith, 2008). For that,  $55^{\circ}\text{C}$  is a rapid and minimum required temperature for pathogen inactivation (Turner, 2002). Indeed, most of the microorganisms could survive well at low temperatures but rapidly die off at temperatures above  $55^{\circ}\text{C}$  (Haug, 1993). When temperatures in compost pile reached as high as  $55^{\circ}\text{C}$  or above, this place microbial

populations present in great stress which become lethal for them along time (Sossou et al., 2014b). Aitken et al. (2007) studied the inactivation of *E. coli* in manure and reported a mean inactivation rate constant ( $k$ ) range in 13.8-15 h<sup>-1</sup> at 55°C. In our study, we reported an inactivation rate constant of 1.55 h<sup>-1</sup> at temperature > 70°C for *E. coli* strain. In the same way, Aitken et al. (2005) and Popat et al. (2010) found for *Ascaris* eggs in sludge at 55°C an inactivation rate constant of 13.30 h<sup>-1</sup> and 3.05 h<sup>-1</sup>, respectively, while in our study we found 0.73 h<sup>-1</sup> at temperature > 70°C. The inactivation rate constants of microorganisms in compost observed during solar heating in this study were significantly less than those of previous reports. This is probably due to the physicochemical characters of the manure, sludge and compost.

The die-off time is usually expressed as a decimal decay (T<sub>90</sub>) or as the time after which organisms are no longer detectable. The maximum survival time of *E. coli*, *E. faecalis* and *Ascaris* eggs during solar box heating was 0.65, 1.19 and 1.37 h, respectively, and during direct sunlight heating was 1.22, 2.56 and 2.94 h, respectively. Turner (2002) conducted a bench-scale study of the inactivation of *E. coli* in sterilized materials and found that at 55°C, *E. coli* was consistently reduced to below detection limits within 2 h. For enterococci, Pike et al. (1988) reported that the T<sub>90</sub> was 31 min in a laboratory-based inactivation experiment with sludge at thermophilic temperatures. At temperatures above 65°C, *Ascaris* egg is destroyed in compost in 1 hour (WEF, 1995). This indicates that only the solar box provided a decimal decay which approached those found by previous authors. However, the solar box heating was not effective for reducing all the microorganisms' population in the compost. The remainder of *E. coli*, *E. faecalis* and *Ascaris* eggs concentration in the compost after 5 hours solar box heating was 2.47 10<sup>3</sup>CFU/g, 1.14 10<sup>4</sup> CFU/g and 65 number of eggs/g, respectively. WHO (2006) reported in the guidelines for verification monitoring in large-scale treatment systems of excreta (compost in our case) that the product is considered safe for use when there is less than 10<sup>3</sup> *E. coli*/g and one helminthes egg/g of dry solid. Thus, the compost heated in the solar box has not yet met the acceptable levels of WHO (2006). Based on the inactivation kinetics of microorganism obtained in this study and considering 5 hours as a daily optimal treatment, total inactivation of *E. coli*, *E. faecalis* and *Ascaris* eggs occurred in the solar box for about 3, 5 and 3 days, respectively. However, this study has not been done in a large-scale. Therefore, care might be taken when applying solar box heating on a large amount of compost.

Comparing the log reduction,  $k_{max}$  and T<sub>90</sub> values, *E. coli* was more affected by the solar heating than *E. faecalis* and *Ascaris* eggs. This is consistent with previous inactivation temperature studies where *E. coli* was more sensitive to heat inactivation (Watcharasukarn et al., 2009). Thus, *E. faecalis* and *Ascaris* eggs were resistant. Previous enterococci monitoring studies had also reported the sigmoidal inactivation of enterococci (Viau and Peccia, 2009), indicating the resistance of this bacteria to adverse conditions (Fisher and Phillips 2009). Besides, *Ascaris* eggs were more resistant to thermal inactivation than other pathogens and are considered the most environmental resistant pathogens excreted in human feces (Moe and Izurieta, 2003; WHO, 2006).



Thermal destruction of pathogens may well depend on factors other than temperature, i.e. pH, moisture content, free ammonia concentration and duration of treatment, which may enhance pathogen inactivation (Turner, 2002). In this study, there was no significant change of physicochemical parameters during heating. Thus, this would indicate that the change of physicochemical parameters did not have effects on microorganisms' inactivation. Therefore time-temperature inactivation was the main process responsible for microorganism decay during solar heating. Exposure temperatures are identified as the principal factor influencing pathogen inactivation in a fecal material (Oropeza et al., 2001). However, Aitken et al. (2007) and Popat et al. (2010) had reported that, the impacts of physicochemical parameters on the inactivation kinetics during heating should exist, but undiscovered.

The decay mechanism of enteric organisms is well defined by time-temperature inactivation. It is generally demonstrated that the increase of temperature has a direct impact on bacterial decay due to the autolysis of bacterial cells (Lang and Smith, 2008; Romdhana et al., 2009). Although the primary inactivation mechanisms of *Ascaris* eggs at high temperatures is not well known, Aitken et al. (2005) and Popat et al. (2010) speculated that the primary inactivation mechanisms of *Ascaris* eggs could be protein capsid denaturation.

Finally, quantification of bacteria in this study was enumerated using a conventional culture method. Although some reports indicated the correlation between culture and direct count method (Viau and Peccia 2009), there is still a need to validate the culture method to the viable cells and not cultivable cells. In the same way, Collick et al. (2007) reported about parasite eggs that to ascertain their viability in stress conditions, count by larvae development is needed compared to direct microscopy count which was used in this study.

#### **5.4. CONCLUSION**

This study was investigated to evaluate the sanitization effectiveness of compost from composting toilet by comparing direct sunlight and solar box heating. The results showed that the temperature regime produced by direct sunlight and solar box during heating were categorized in mesophilic (>30°C) and pasteurization (>70°C), respectively. The log reduction of microorganisms in heated compost by solar box was significantly higher than that of the sun. The inactivation rate was slower in compost heated by direct sunlight but fast in compost heated by solar box. *E. coli* appears to be the most sensitive to destruction temperatures achieved by solar heating. The thermal decimal decay occurred rapidly in solar box while it was prolonged with direct sunlight. The high and uniform temperature distribution obtained with solar box during heating proved to be an efficient option for safe use of compost.

## 5.5. REFERENCES

- Aitken, M. D., Sobsey, M. D., Blauth, K. E., Shehee, M., Crunk, P. L., Walters, G. W. (2005) Inactivation of *Ascaris suum* and poliovirus in biosolids under thermophilic anaerobic digestion conditions. *Environmental Science & Technology*, 39(15), 5804-5809.
- Aitken, M. D., Sobsey, M. D., Van Abel, N. A., Blauth, K. E., Singleton, D. R., Crunk, P. L., Nichols, C., Walters, G. W. and Schneider, M. (2007) Inactivation of *Escherichia coli* O157: H7 during thermophilic anaerobic digestion of manure from dairy cattle. *Water Research*, 41(8), 1659-1666.
- Bux, M., Baumann, R., Philipp, W., Conrad, T. and Muhlbauer, W. (2001) Class-A by solar drying recent experiences in Europe. *Proceedings of the Water Environment Federation, 2011(12)*, 309-317. *Water Environment Federation's Technical Exhibition and Conference 01*, Atlanta, USA.
- Collick, A. S., Inglis, S., Wright, P., Steenhuis, T. S. and Bowman, D. D. (2007) Inactivation of in a biodrying compost system. *Journal of Environmental Quality*, 36(5), 1528-1533.
- Eaton, A. E., Clesceri, L. S., Rice, E. W. and Greenberg, A. E. (2005) Standard Methods for the Examination of Water and Wastewater. American Public Health Association, American Water Works Association, Water Environment Federation, Washington DC, USA.
- Fisher, K. and Phillips, C. (2009) The ecology, epidemiology and virulence of *Enterococcus*, *Microbiol*, 155 (6), 1749-1757.
- Geeraerd, A. H., Valdramidis, V. P. and Van Impe, J. F. (2005) GInaFiT, a freeware tool to assess non-log-linear microbial survivor curves. *International Journal of Food Microbiology*, 102(1), 95-105.
- Ghaly A. E. and MacDonald K. N. (2012) An effective passive solar dryer for thin layer drying of poultry manure. *American Journal of Engineering and Applied Sciences*, 5, 136-150.
- Haug R. (1993) *The Practical Handbook of Compost Engineering*, Lewis Publishers, New York, USA.
- Jiménez, B., Drechsel, P., Kone, D., Bahri, A., Raschid-Sally, L. and Qadir, M. (2009) 'Wastewater, sludge and excreta use in developing countries: An overview', in P. Drechsel, C.A. Scott, L. Raschid-Sally, M. Redwood and A. Bahri (eds.), *Wastewater Irrigation and Health: Assessing and Mitigating Risk in Lowincome Countries*, Earthscan, London, UK.

- Lang, N. L. and Smith, S. R. (2008) Time and temperature inactivation kinetics of enteric bacteria relevant to sewage sludge treatment processes for agricultural use. *Water Research*, 42(8), 2229-2241.
- Mathioudakis, V. L., Kapagiannidis, A. G., Athanasoulia, E., Diamantis, V. I., Melidis, P. and Aivasidis, A. (2009) Extended dewatering of sewage sludge in solar drying plants. *Desalination*, 248(1), 733-739.
- Mnkeni, P. N. S. and Austin, L. M. (2009) Fertilizer value of human manure from pilot urine-diversion toilets. *Water SA.*, 35(1), 133-138.
- Moe, C. L. and Izurieta, R. (2003) Longitudinal study of double vault urine diverting toilets and solar toilets in El Salvador. *Proceedings of the 2<sup>nd</sup> Symposium on Ecological Sanitation*, 7–11 April 2003, Lubeck, Germany.
- Mote, C. R., Emerton, B. L., Allison, J. S., Dowlen, H. H. and Oliver, S. P. (1988) Survival of coliform bacteria in static compost piles of dairy waste solids intended for freestall bedding. *Journal of Dairy Science*, 71(6), 1676-1681.
- Niwagaba, C., Nalubega, M., Vinnerås, B., Sundberg, C. and Jönsson, H. (2009) Bench-scale composting of source-separated human feces for sanitation. *Waste Management*, 29(2), 585-589.
- Nosrati, M., Shojaosadati, S. A. and Sreerishnan, T. R. (2006) Thermophilic Aerobic Digestion of Activated Sludge; Reduction of Solids and Pathogenic Microorganisms. *Iranian Journal of Chemistry and Chemical Engineering*, 25(1), 67-71.
- Ögleni, N. and Özdemir, S. (2010) Pathogen reduction effects of solar drying and soil application in sewage sludge. *Turkish Journal of Agriculture and Forestry*, 34(7), 509-515.
- Oropeza, M. R., Cabirol, N., Ortega, S., Ortiz, L. P. C. and Noyola, A. (2001) Removal of fecal indicator organism and parasites (fecal coliforms and helminthes eggs) from municipal biologic sludge by anaerobic mesophilic and thermophilic digestion. *Water Science and Technology*, 44(4), 97-101.
- Ozdemir, S., Aslan, T., Celebi, A., Dede, G. and Dede, O. H. (2013) Effect of solarization on the removal of indicator microorganisms from municipal sewage sludge. *Environmental Technology*, 34(12), 1497-1502.
- Paluszak, Z., Skowron, K., Sypuła, M. and Skowron, K. J. (2012) Microbiological Evaluation of the Effectiveness of Sewage Sludge Sanitization with Solar Drying Technology. *International Journal of Photoenergy*, 2012, 1-11.

- Pecson, B. M., Barrios, J. A., Jiménez, B. E. and Nelson, K. L. (2007) The effects of temperature, pH, and ammonia concentration on the inactivation of *Ascaris* eggs in sewage sludge. *Water Research*, 41(13), 2893-2902.
- Pike, E. B., Carrington, E. G., Harman, S. A. (1988) Destruction of Salmonellas, enteroviruses and ova of parasites in wastewater sludge by pasteurization and anaerobic digestion. *Water Science and Technology*, 20(12), 337-343.
- Popat, S. C., Yates, M. V. and Deshusses, M. A. (2010) Kinetics of inactivation of indicator pathogens during thermophilic anaerobic digestion. *Water Research*, 44(20), 5965-5972.
- Rendall, J. D. (2012) Solar Compartment Design Methods, Performance Analysis and Thermal Data for Solar Composting Latrines: A Full Scale Experimental Study, M.S. thesis, Department of Civil, Environmental, and Architectural Engineering, University of Kansas.
- Renner, P. and Peters, J. (1999) Resistance of enterococci to heat and chemical agents, *Zentralblatt für Hygiene und Umweltmedizin*, 202(1), 41-50.
- Romdhana, M. H., Lecomte, D., Ladevie, B. and Sablayrolles, C. (2009) Monitoring of pathogenic microorganisms contamination during heat drying process of sewage sludge, *Process Safety and Environmental Protection*, 87(6), 377-386.
- Schwartzbrod, J. (2003) Quantification and Viability Determination for Helminth Eggs in Sludge (Modified US EPA Method 1999). University of Nancy, France. Unpublished paper.
- Sossou, S. K., Hijikata, N., Sou, M., Tezuka, R., Maiga, A. H., and Funamizu, N. (2014) Inactivation mechanisms of pathogenic bacteria in several matrixes during the composting process in a composting toilet. *Environmental Technology*, 35(6), 674-680.
- Sossou, S. K., Sou/Dakoure, M., Hijikata, N., Quenum, A., Maiga, A. H. and Funamizu, N. (2014) Removal and deactivation of intestinal parasites in aerobic mesophilic composting reactor for urine diverting composting toilet. *Compost Science and Utilization*, 22(4), 242-252.
- Sypuła, M., Paluszak, Z. and Szala, B. (2013) Effect of Sewage Sludge Solar Drying Technology on Inactivation of Select Indicator Microorganisms. *Polish Journal of Environmental Studies*, 22(2), 533-540.
- Turner, C. (2002) The thermal inactivation of *E. coli* in straw and pig manure. *Bioresource Technology*, 84(1), 57-61.
- Viau, E. and Peccia, J. (2009) Evaluation of the enterococci indicator in biosolids using culture-based and quantitative PCR assays. *Water Research*, 43(19), 4878-4887.

- Vinnerås, B. (2007) Comparison of composting, storage and urea treatment for sanitising of fecal matter and manure. *Bioresource Technology*, 98(17), 3317-3321.
- Vinnerås, B., Björklund, A. and Jönsson, H. (2003) Thermal composting of fecal matter as treatment and possible disinfection method-laboratory-scale and pilot-scale studies. *Bioresource Technology*, 88(1), 47-54.
- Watcharasukarn, M., Kaparaju, P., Steyer, J. P., Krogfelt, K. A. and Angelidaki, I. (2009) Screening *Escherichia coli*, *Enterococcus faecalis*, and *Clostridium perfringens* as indicator organism in evaluating pathogen reducing capacity in biogas plants. *Environmental Microbiology*, 58(2), 2221-2230.
- WEF (1995) Wastewater Residuals Stabilization, Manual of Practice No. FD-9. Water Environmental Federation, Alexandria, VA, 22, 1-34, New York, USA.
- WHO (2006) Guidelines for the Safe Use of Wastewater, Excreta and Greywater: Policy and regulatory aspects, World Health Organization (Ed.), Vol. 4, Geneva, Switzerland.

## Chapter 6

### POST-TREATMENT BY UREA ADDITION FOR SANITIZING COMPOST FROM COMPOSTING TOILET

#### 6.1. INTRODUCTION

On-site sanitizing is still the main solution for the majority of the world's population, serving over 3 billion people, mainly in low- and middle-income countries (WHO/UNICEF, 2013). However, excreta management remains a thorny issue in these countries where some part of this fecal matter is used without treatment as fertilizer (Jiménez et al., 2009). Indeed, toilet waste fractions obtained from households contain the major proportion of nutrients (Vinnerås et al., 2003) with a high risk of pathogen content and which have to be disinfected before use as fertilizer or soil conditioner. Producing a safe fertilizer from human feces enables to break the fecal-oral transmission route via emission to the recipient water and contaminated food. To avoid this transmission through the food chain, contamination has to be gotten rid of as early as possible.

Common technologies applied in on-site sanitizing of humans feces include the use of different types of latrines, septic tanks, and dry/or composting toilets (Mnkeni and Austin, 2009). The most common treatment is composting, where the main inactivation of pathogens is due to increased temperature (WHO, 2006). Composting is a naturally occurring aerobic process, whereby native microorganisms convert mainly biodegradable organic matter to carbon dioxide and residue, remained as humus like compounds (Lopez Zavala et al., 2004). During composting process, it is assumed that two goals are achieved: (1) the feces and bulking materials are biodegraded and transformed into organic compost, and (2) pathogens in the feces are inactivated for protection of human health. Indeed, the most important, from the view point of standards for the protection of public health, are relating to the presence or absence of pathogens (Lasaridi et al., 2006). However, in most cases, the temperature in composting toilet in some decentralized areas, do not get high rise to destroy all pathogens (Sossou et al., 2014a). Therefore, the compost from composting toilet, aside from being stabilized, is hygienically unsafe, and need appropriate sanitizing treatment.

Low-temperature degradation of fecal material, i.e. storage, requires a treatment time exceeding a year (WHO, 2006) and even that the product cannot be considered as pathogen-free. The practice of adding inert material e.g. ash or lime as alkaline treatment can ensure a safe reuse of compost. Indeed, the addition of ash or lime leads to a quick rise in pH and, initially, a rapid die-off of pathogens. However, this effect declines over time due to a decrease in pH and subsequent regrowth (Magri et al., 2013). Furthermore, addition of ash or lime is complicated by the formation of cement lumps and insoluble salts after soil amendment (Ottoson et al., 2008). Therefore, one of the most alternative used nitrogen fertilizers in the world is urea. When applied to soil it is converted to ammonia and carbon dioxide by the enzyme urease. The same effect should occur when urea is added to compost. The lower pH and higher content of organic material in compost result in a slower reduction

in pathogens during the plain storage and additional treatment to increase ammonia content or pH is needed. Besides, the alkaline pH provided by urea influences the  $\text{NH}_4^+(\text{aq})/\text{NH}_3(\text{aq})$  equilibrium to move towards the microbiocidal  $\text{NH}_3$ , as does increased temperature (Emerson et al. 1975). One advantage with ammonia-based sanitation is that the ammonia is not consumed during the treatment, but remains in the treated material and increased the fertilizer value (Nordin et al., 2009).

Several studies have reported the inactivation based on intrinsic ammonia or added ammonia amendments, e.g. urea  $[(\text{NH}_2)_2\text{CO}]$ , of human feces (Nordin et al., 2009), manure (Vinnerås et al., 2007) and sludge (Fidjeland et al., 2013). However, the effectiveness of these treatments on compost has not been studied yet. The lack of information about urea treatment in sub-sahelian climate indicates the necessity for further studies to provide monitorable factors on microbial die-off. Investigation on the possibility of applying a reliable and simple method in the sanitizing of compost, could shortened the storage time and minimize handling of compost. Inactivation rate, or the degree of decay, can be used to assess and compare the quantitative effectiveness of a treatment process on pathogens destruction (Lang and Smith, 2008). This study aimed to estimate the sanitizing effectiveness of urea addition on compost as alkaline treatment by comparing different urea concentrations at different temperatures.

## **6.2. MATERIALS AND METHODS**

### **6.2.1. Compost collection**

Composts used for the experiments were collected from a urine-diverting composting toilet prototype installed in a pilot household located in Ouagadougou, the capital city of Burkina Faso. This toilet was coupled with an aerobic composting reactor and was used by 8-10 persons with a total produced compost of 6 to 8kg for approximately 2 months. The matrix used as bulking agent was sawdust and there were no inert material source addition (ash or lime) as alkaline treatment. Composts were collected and transported to the laboratory within 5 h and stored at 4°C before setting up the experiment. The compost was not autoclaved.

### **6.2.2. Microbial suspension preparation**

In order to assess the entire inactivation process, compost was inoculated by selected indicator bacteria and parasite eggs. The bacteria strains, *Escherichia coli* ATCC 25922 and *Enterococcus faecalis* ATCC 29212, used in this study were purchased from the American Type Culture Collection (ATCC, USA). For suspension preparation, each bacteria, *E. coli* and *E. faecalis*, were cultured in a growth medium Nutrient Broth (Difco, France) and incubated in a shaking water bath at 37°C overnight. The bacteria suspensions were used as a source of inoculums. The parasites used were *Ascaris lumbricoides* eggs which were extracted from human feces collected from patients at hospital in Ouagadougou, Burkina Faso. According to the method of Collick et al. (2007), the feces collected were washed through a series of sieves ranging from 425 to 38  $\mu\text{m}$ . Eggs were finally collected on the 38- $\mu\text{m}$  sieve and stored in a 4°C refrigerator in reverse osmosis water and 10% formaldehyde to prevent molds growth. Upon use, a portion of the eggs solution was collected as a source of inoculums.

### 6.2.3. Urea treatment set up

Compost was subsequently treated with urea (Urea Technical grade, Rosier SA, Belgium) at different concentrations from 0% to 2% (w/w), where the 0% control represented closed storage of untreated compost. Urea additions of 0.5–2% (w/w) were made based on wet weight and the moisture content of compost was adjusted to 20% (w/w) with sterilized deionized water. Approximately 300 g of compost with or without urea was transferred to 500 ml plastic bottles. For compost inoculation, an adequate aliquot of *E. coli* and *E. faecalis* (0.3mL about  $10^6$ - $10^7$  CFU/mL), and *Ascaris* eggs (1mL about  $10^3$ - $10^4$  eggs) was added. This concentration of microorganisms was added to insure that the levels of microorganisms tested were high enough to study their decrease in viability during treatment. The bottle was only partially closed with a lid, allowing some ventilation otherwise the bottle would burst due to generation of gases from the compost during storage. Subjected to different urea concentrations 0.5–2%, compost treated was performed at the same incubation temperature (32°C). Subjected to the same urea concentration (2%), compost treated was performed at different incubation temperatures (22 and 42°C) representing the range of ambient temperature in Burkina Faso's sub-sahelian climate. The pH, aqueous ammonia (NH<sub>3</sub>(aq)) and microorganisms viability were monitored at regular time intervals depending on the incubation temperatures.

### 6.2.4. Measurements of pH and aqueous ammonia (NH<sub>3</sub> (aq))

The pH was determined with a Hanna Digital Compo Meter (HI991405, Hanna, UK) in compost suspension in de-ionized water at the ratio of 1:5 (w:v) after 30 min shaking at room temperature. Total ammonium was measured with a spectrophotometer Thermo Aquamate (Thermo Electron Co., USA) using the indophenol blue method (Merck; Whitehouse Station, NJ). The concentration of aqueous ammonia (NH<sub>3</sub> (aq)) was calculated from the measured total ammonium, pH and temperature according to Emerson et al. (1975) using the dissociation constant  $pK_a=0.09018+2729.92/T$ .

### 6.2.5. Measurements of indicator microorganisms

For bacteria extraction, a 3% (w/v) beef extraction solution was used. Ten (10) g of compost sample was added to a 90 ml volume of extracted solution and agitated for 3 minutes to extract bacteria. After adequate dilution (7 fold) with phosphate buffer, each extracts were inoculated by double layer method in chromocult coliform agar ES (Difco, France) for *E. coli* and Slanetz-Bartley agar (Difco, France) for *Enterococcus* spp., including *E. faecalis* added. These inoculated media were incubated at 37°C for 24 h for *E. coli* colonies count and at 37°C for 48 h for *Enterococcus* colonies count. The detection limits of bacteria were 10 CFU/g and the concentration of bacteria count was expressed in CFU/g of dry compost.

For parasites analysis, 10 g of compost sample were homogenized with 90 mL of 0.1% Tween 80 for 1 min using a blender and screened through 4 layers of folded gauze compress. The filtrate was collected in round bottom flasks and allowed to settle for 3 hours. The number of *A.* eggs was determined by the concentration method followed by a direct count under optical microscope (B-350, OPTIKA, Italy), the method of US EPA protocol (1999)



modified by Schwartzbrod (2003) and described by Sossou et al. (2014a). The viability of *A.* eggs was assessed both by morphological analysis for integrity (cellular normal structure) and by a staining exclusion dyeing method using the Safranin O. If the dye had penetrated into the eggs, they were counted as no-viable. The detection limits of *A.* eggs were one egg/g and the number of *A.* eggs count was expressed in number of eggs/1000g of dry compost.

### 6.2.6. Data analysis

Log10 transformed microorganisms' counts were subjected to microbial inactivation rate kinetics by using the Geeraerd and Van Impe Inactivation Model Fitting Tool (GInaFiT) (Geeraerd et al., 2005). This model is used to analyze concave inactivation curves including those exhibiting a lag phase before a first-order inactivation. Therefore, the best-fitting models were the log-linear regression (Eq. 1) for *E. coli* and *Enterococcus*, and the log-linear regression plus shoulder (Eq. 2) for *A.* eggs. All models were run for each inactivation curve and the values of the Root Mean Sum of Squared Errors (RMSE) were compared to select the best fit. The inactivation rate  $k_{max}$  ( $h^{-1}$ ) and T90 values (time to inactivate 90% of the population) were calculated using the best fitting model in GInaFiT.

$$N(t) = N(0).e^{-k_{max}.t} \quad \text{(Equation 6. 1.)}$$

$$N(t) = N(0).e^{-k_{max}.t} \cdot \frac{e^{k_{max}.Sl}}{1+(e^{k_{max}.Sl}-1).e^{-k_{max}.t}} \quad \text{(Equation 6. 2.)}$$

Where,  $N(t)$  and  $N(0)$  expressed in CFU or number of eggs/g of dry compost, are the concentration of microorganism in compost at time  $t$  and 0;  $t$  is the reaction time (h). The parameters used for the estimation by GInaFiT were  $Sl$  (shoulder length i.e., the length of the lag phase) (h), which represents the degrees of freedom. The inactivation rate  $k_{max}$  values and standard deviation were calculated directly by GInaFiT program.

All results are expressed as the mean value of triplicate aliquots of compost sampled. The effect of compost with or without urea, time and their interaction with pH,  $NH_3(aq)$  concentration and temperature was analyzed. Data results were subjected to t-test to assess significant difference and one-way analysis of variance (ANOVA) to compare the effects of the different urea concentrations and temperatures. Treatment means were compared with at least, corresponding significant  $p$  value. These statistical analyses were performed using the StatView software version 5.0 (SAS Institute Inc., Cary, NC, USA).

## 6.3. RESULTS AND DISCUSSION

### 6.3.1. pH and ammonia in the compost during urea treatment at different concentrations

The change of pH and ammonia concentration in the compost during urea treatment at 32°C was presented in the Fig. 6.1 and 6.2, respectively. The pH in the untreated compost (0% urea) was around 7.6 and urea addition of 0.5%-2% (w/w) increased the pH to 8.8-9.7. From urea 0.5% to 2% (w/w) the value of pH increased by 0.9 units after urea addition and there were no significant variation ( $p < 0.05$ ) during the treatment.

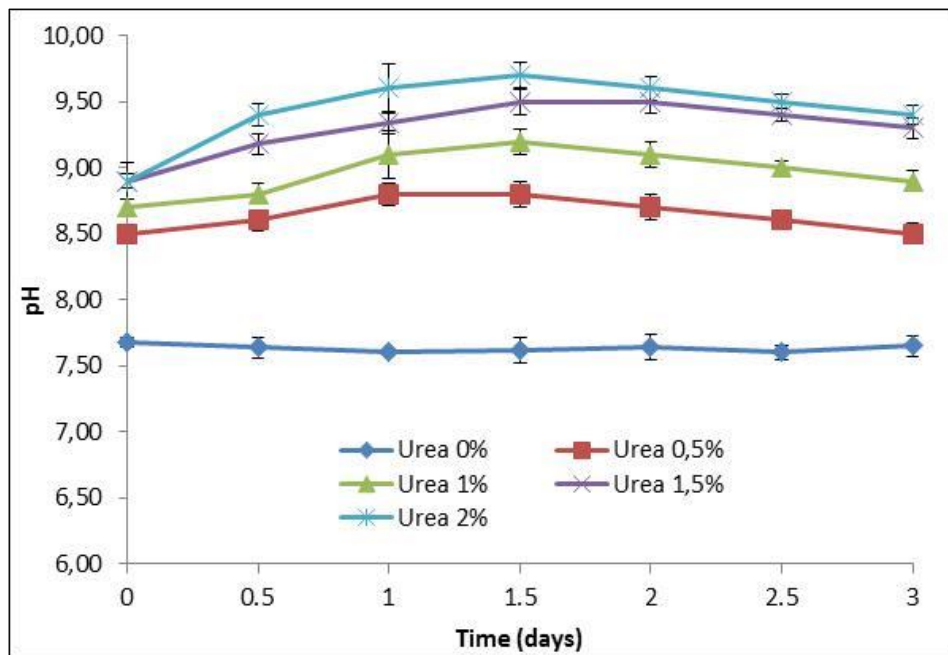

Figure 6. 1. Change of pH values during urea treatment at different urea concentrations

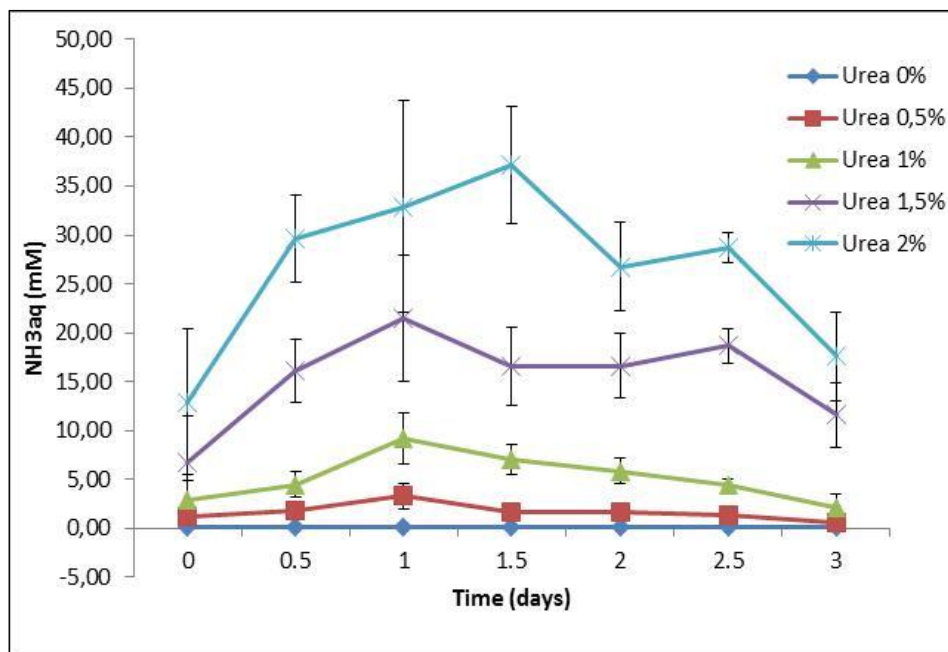

Figure 6. 2. Change of ammonia concentrations during urea treatment at different urea concentrations

However, the peak of pH changes ( $\Delta\text{pH} = 1.2$  units) were obtained by applying the first urea dose from 0.5%. The pH of untreated compost was lower ( $p < 0.0001$ ) compared to that of urea-treated compost (0.5-2%). At the same time, in the untreated compost, the  $\text{NH}_3(\text{aq})$  concentration remained very low (between 0.07-0.09 mM) throughout the 3 days study

period. However, the  $\text{NH}_3(\text{aq})$  concentration in the urea-treated compost increased and decrease during the treatment. The peak of  $\text{NH}_3(\text{aq})$  concentration of 0.5%-2% (w/w) urea-treated compost was 3.3, 9.23, 21.49 and 37.16 mM, respectively. The initial  $\text{NH}_3(\text{aq})$  concentrations in the urea-treated compost was correlate to the different urea concentrations added.

### 6.3.2. pH and ammonia in the compost during urea treatment at different temperatures

The change of pH and ammonia concentration in the compost during urea treatment at different temperatures (22, 32, 42°C) was presented in Fig. 6.3 and 6.4, respectively. Subjected to the same urea treatment (2%), the pH in urea-treated compost at different temperatures 22, 32, 42°C increased to the peak 9.4, 9.7 and 9.9, respectively, but there were no significant variation ( $p < 0.05$ ) during the treatment. In addition, the different incubation temperatures result in no significant difference ( $p < 0.05$ ) in the pH values after urea addition. At the same time, the  $\text{NH}_3(\text{aq})$  concentrations in the urea-treated compost increased and decrease during the treatment. The peak of  $\text{NH}_3(\text{aq})$  concentration of urea-treated compost at 22, 32, 42°C was 6.44, 37.16 and 232.47 mM, respectively. The peak were higher ( $p < 0.05$ ) at higher temperatures (32, 42°C) and remained fairly stable at low temperature (22°C). Only a slight increase in  $\text{NH}_3(\text{aq})$  levels over time in untreated compost was observed at 22°C.

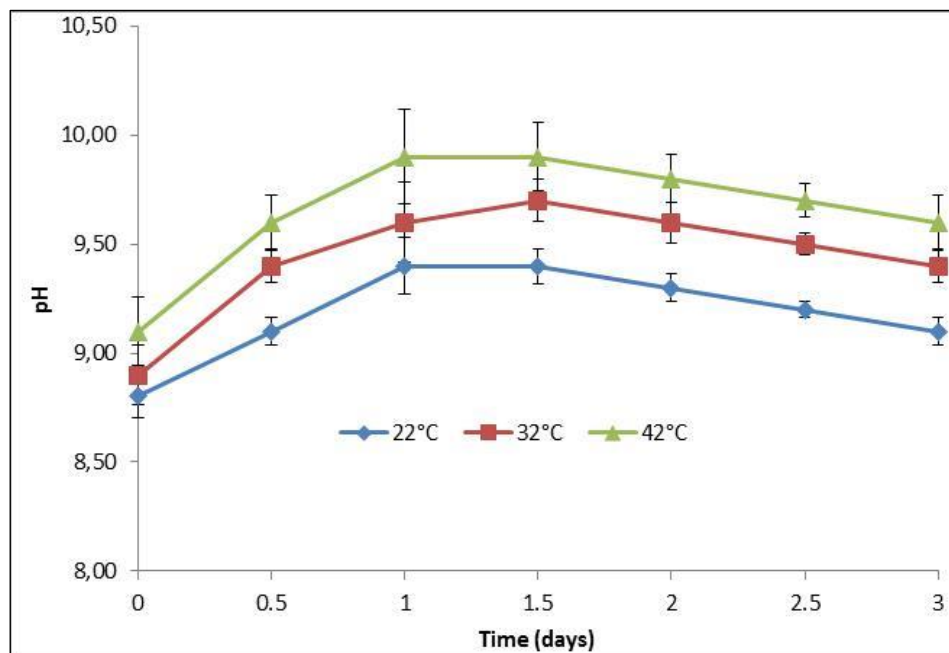

Figure 6. 3. Change of pH values during urea treatment at different temperatures

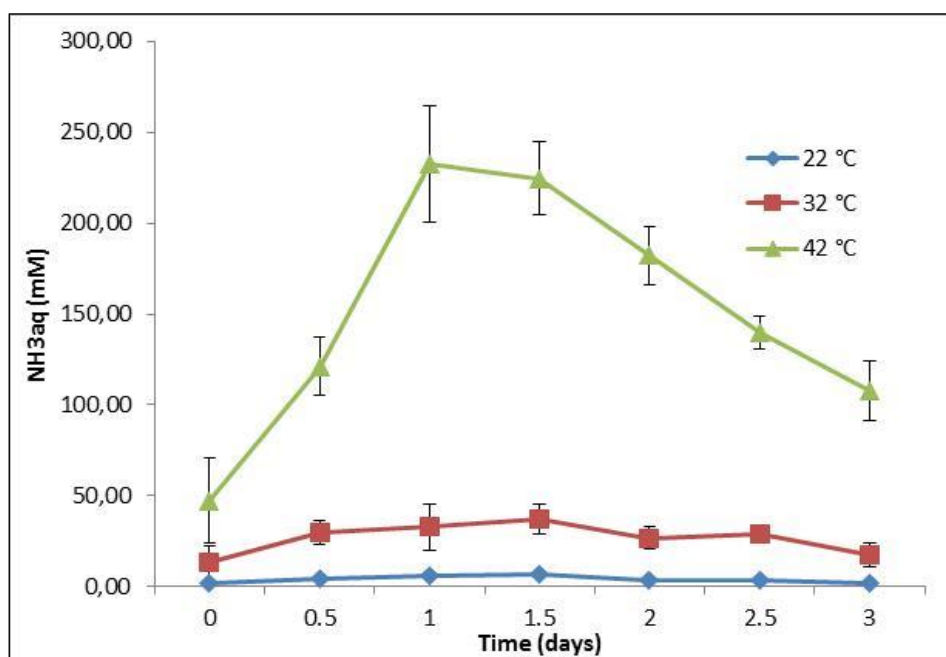

Figure 6. 4. Change of ammonia concentrations during urea treatment at different temperatures

### 6.3.3. Survival of indicator microorganisms in compost during urea treatment at different urea concentrations

The change of the number of *E. coli*, *Enterococcus* and *A.* eggs during urea treatment at different concentrations are presented in Fig. 6.5, 6.6 and 6.7, respectively. The results showed that, urea treatment has reduced the number of microorganisms tested. The change of *E. coli* and *Enterococcus* populations in urea-treated compost showed a linear curve of regression. After 3 days treatment, the number of *E. coli* decreased to average of about 0.62, 0.90, 0.97, 1.41 and 1.57-log reduction for 0, 0.5, 1, 1.5 and 2% urea concentration, respectively. At the same time, the number of *Enterococcus* isolated, decreased to average of about 0.35, 0.75, 0.89, 1.25 and 1.32-log reduction for 0, 0.5, 1, 1.5 and 2% urea concentration, respectively. The linear regression analysis indicated that, there was a significant decay ( $p < 0.001$ ) in the log number of *E. coli* and *Enterococcus* during urea treatment in relation with incubation time. The inactivation curves of *A.* eggs, showed two phases: a lag phase as an initial slight decrease followed by a rapid decrease corresponding to log-linear and shoulder decay. The reduction in the *A.* eggs population during urea treatment was an average of about 0.15, 0.42, 0.63, 0.91 and 1.06-log reduction for 0, 0.5, 1, 1.5 and 2% urea concentration, respectively. The non-linear regression analysis of *A.* eggs indicated that, there was a significant decay ( $p < 0.001$ ) in the log number during urea treatment in relation with incubation time. For all microorganisms tested, their number in urea-treated compost declined more rapidly in high urea concentration (1.5-2%) than in low urea concentration (0-1%). Therefore, the log reduction of indicator microorganisms was positively correlated to the urea concentration.

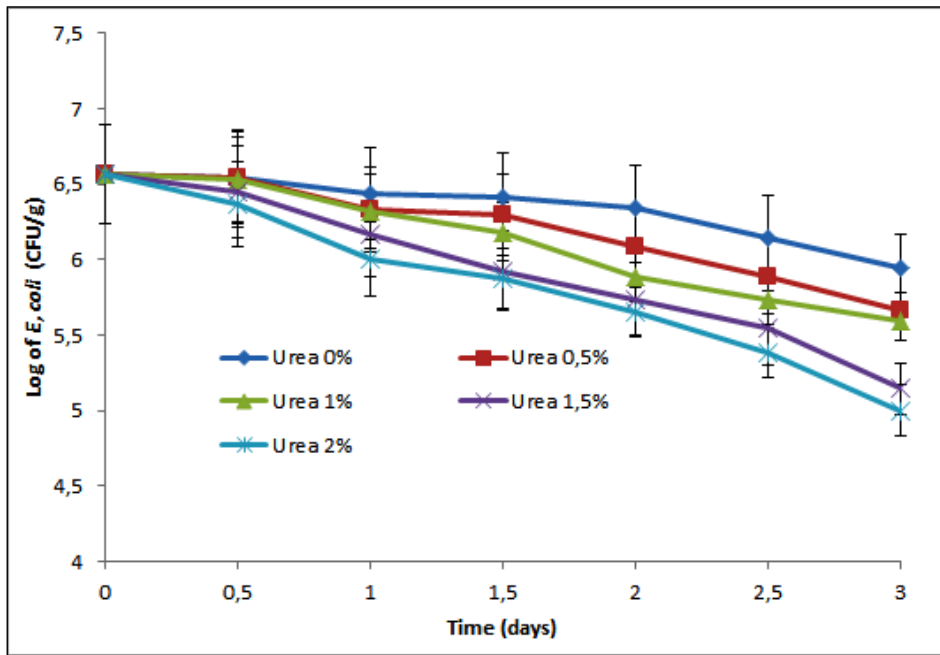

Figure 6. 5. Change of *E. coli* during urea treatment

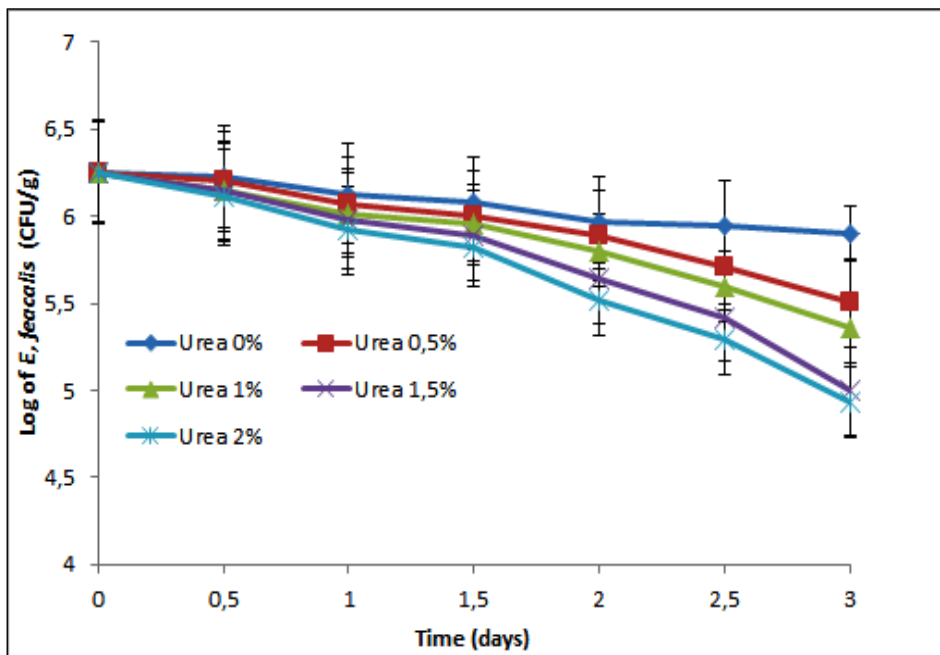

Figure 6. 6. Change of *E. faecalis* during urea treatment

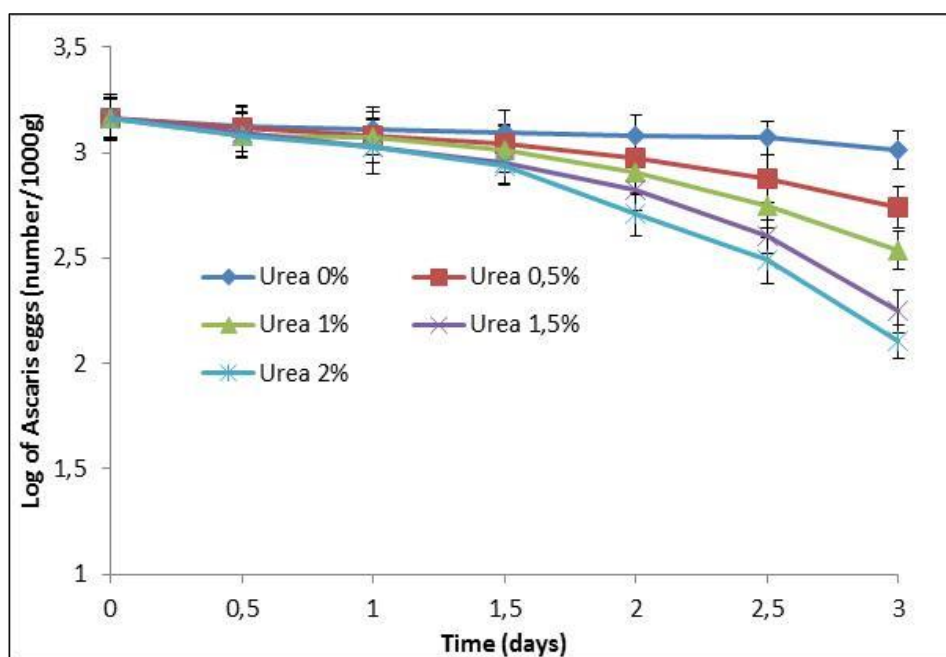

Figure 6. 6. Change of *Ascaris* eggs during urea treatment

#### 6.3.4. Survival of indicator microorganisms in compost during urea treatment at different temperatures

The reduction of *E. coli*, *Enterococcus* and *A.* eggs during urea treatment at different temperatures (22, 32 and 42°C) varied. The linear reduction of *E. coli* showed an average of about 0.46, 1.57 and 3.54-log reduction at temperatures 22, 32 and 42°C, respectively. For *Enterococcus*, the linear reduction was an average of about 0.34, 1.32 and 4.48-log reduction at temperature 22, 32 and 42°C, respectively. The non-linear reduction of *A.* eggs showed an average of about 0.22, 1.06 and 4.87-log reduction at temperatures 22, 32 and 42°C, respectively. For all microorganisms tested, their number in urea-treated compost declined more rapidly in compost incubated at high temperatures (32 and 42°C) than at a low temperature (22°C). In addition, the log reduction of indicator microorganisms in compost during urea treatment was positively correlated with incubation temperatures.

#### 6.3.5. Inactivation rate and decay of microorganisms in compost during urea treatment at different concentrations and temperatures

The estimated maximum inactivation rate constant ( $k_{max}$ ) and the decimal decay (T90) of indicator microorganisms during urea treatment at different concentrations and temperatures were presented in Table 6.1. The  $k_{max}$  of *E. coli*, was 0.13; 0.21; 0.26; 0.39 and 0.48 day<sup>-1</sup> for 0; 0.5; 1; 1.5 and 2% urea concentration, respectively. At the same time, the  $k_{max}$  of *Enterococcus* were 0.11; 0.18; 0.24; 0.30 and 0.35 day<sup>-1</sup> for 0, 0.5, 1, 1.5 and 2% urea concentration, respectively. For *A.* eggs, the  $k_{max}$  was 0.05, 0.10, 0.14, 0.19 and 0.22 day<sup>-1</sup> for 0, 0.5, 1, 1.5 and 2% urea concentration, respectively. For all microorganisms tested,  $k_{max}$  was significantly high ( $p < 0.001$ ) at high urea concentration (1.5-2%) than that of low urea concentration (0-1%). This indicated that, the inactivation was fast in high urea-treated

compost and slower in low urea-treated compost. The T90 of *E. coli* was 7.6, 4.6, 3.7, 2.5 and 2.1 days for 0, 0.5, 1, 1.5 and 2% urea concentration, respectively. At the same time, the T90 of *Enterococcus* was 8.8, 5.4, 4.1, 3.3 and 2.8 days for 0, 0.5, 1, 1.5 and 2% urea concentration, respectively. For *A. eggs*, the T90 was 19.2, 9.7, 6.9, 5.4 and 4.6 days for 0, 0.5, 1, 1.5 and 2% urea concentration, respectively. For all microorganisms tested, the T90 was shorter at high urea concentration (1.5-2%) than that of low urea concentration (0-1%). This revealed that, the decimal decay T90 occurred rapidly in high urea-treated compost while it was prolonged in low urea-treated compost.

Subjected to the same urea treatment (2%), the *kmax* of *E. coli* in treated compost, was 0.14, 0.48 and 1.08 day<sup>-1</sup> at temperatures 22, 32 and 42°C, respectively. At the same time, the *kmax* of *Enterococcus* in urea-treated compost was 0.09, 0.35 and 0.89 day<sup>-1</sup> at temperatures 22, 32 and 42°C, respectively. For *A. eggs*, the *kmax* was 0.04, 0.22 and 0.71 day<sup>-1</sup> at temperatures 22, 32 and 42°C, respectively. For all microorganisms tested, the *kmax* was significantly high ( $p < 0.001$ ) at high temperatures (32 and 42°C) than that at low temperature (22°C). This indicated that, the inactivation was fast in incubated urea-treated compost at high temperatures (32 and 42°C) and slower in incubated urea-treated compost at low temperature (22°C). The T90 of *E. coli* in compost was 7.1, 2.1 and 0.9 days at temperatures 22, 32 and 42°C, respectively. At the same time, the T90 of *Enterococcus* spp. in urea-treated compost was 11.1, 2.8 and 1.1 days at temperatures 22, 32 and 42°C, respectively. For *A. eggs*, the T90 was 25; 4.6 and 1.4 days at temperatures 22, 32 and 42°C, respectively. For all microorganisms tested, the T90 was shorter in urea-treated compost at high temperature (32 and 42°C) than that of low temperature (22°C). This revealed that, the decimal decay occurred rapidly in urea-treated compost at high temperature while it took time at low temperature.

Table 6. 1. Maximum inactivation rate constant (*kmax*) and decimal decay rate (T90) of regression lines of microorganisms during urea treatment

Urea	<i>kmax</i> ± RMSE (day <sup>-1</sup> )			T90 (days)		
	<i>E. coli</i>	<i>Enterococcus</i>	<i>A. eggs</i>	<i>E. coli</i>	<i>Enterococcus</i>	<i>A. eggs</i>
0%	0.13 <sup>a</sup> ± 0.07	0.11 <sup>a</sup> ± 0.02	0.05 <sup>a</sup> ± 0.01	7.6	8.8	19.2
0.5%	0.21 <sup>a</sup> ± 0.07	0.18 <sup>a</sup> ± 0.05	0.10 <sup>a</sup> ± 0.01	4.6	5.4	9.7
1% 32°C	0.26 <sup>a</sup> ± 0.06	0.24 <sup>a</sup> ± 0.06	0.14 <sup>a</sup> ± 0.02	3.7	4.1	6.9
1.5%	0.39 <sup>b</sup> ± 0.06	0.30 <sup>b</sup> ± 0.11	0.19 <sup>a</sup> ± 0.03	2.5	3.3	5.4
22°C	0.14 <sup>a</sup> ± 0.07	0.09 <sup>a</sup> ± 0.03	0.04 <sup>a</sup> ± 0.01	7.1	11.1	25
2% 32°C	0.48 <sup>b</sup> ± 0.06	0.35 <sup>b</sup> ± 0.09	0.22 <sup>b</sup> ± 0.03	2.1	2.8	4.6
42°C	1.08 <sup>b</sup> ± 0.06	0.89 <sup>b</sup> ± 0.08	0.71 <sup>b</sup> ± 0.03	0.9	1.1	1.4

\* For each microorganism, values followed by the same letter are not significantly different for  $p < 0.0$

### 6.3.6. Discussion

The experimental protocol described in this study was designed to evaluate the survival of indicator microorganisms in compost during urea treatment at different concentrations and temperatures. During treatment time, the inactivation of indicator microorganisms in the compost was assessed in relation to pH, ammonia content and temperature.

The initial pH (7.6) of the fresh compost used in this study, tend to alkaline pH. This alkaline pH may be the result of the increase of pH during the natural composting process obtained in the composting toilet (Sossou et al., 2014a). The addition of urea to the compost increased the pH, which might be due to enzymatic conversion of the added urea to ammonium ( $\text{NH}_4^+$ ) by urease secreted by bacteria present in the compost (Mobley and Hausinger, 1989). During the urea treatment, the pH increased and tend to stabilize, this an important prerequisite for the formation of both  $\text{NH}_3$  and  $\text{CO}_3^{2-}$ . In general, it is difficult to achieve a stable pH during the alkaline treatment of biomaterial below pH 12 and a decline in pH is most often observed (Pecson et al. 2007). This variation of pH levels is likely a main factor behind the observed differences in ammonium  $\text{NH}_3(\text{aq})$  levels between the different urea concentrations added. Total ammonium ( $\text{NH}_3$ ) will be mostly in  $\text{NH}_4^+$  form whereas the increase in pH dramatically increases the conversion  $\text{NH}_4^+$  to  $\text{NH}_3$  (Philippe et al., 2011).

Subjected to the same urea treatment (2%), the pH value increased with increase of temperature. However, the incubation temperatures did not result in significant difference of pH values in compost. The  $\text{NH}_3(\text{aq})$  levels in urea-treated compost also increased with temperatures. This increase in  $\text{NH}_3(\text{aq})$  levels might be due to a temperature mediated shift in the equilibrium between  $\text{NH}_4^+$  and  $\text{NH}_3$  towards  $\text{NH}_3$  (Philippe et al., 2011). Indeed, in the aqueous phase, ammonium ( $\text{NH}_4^+$ ) and ammonia ( $\text{NH}_3$ ) are in an equilibrium which is influenced by temperature and pH. The decrease in level of  $\text{NH}_3(\text{aq})$  over time at 32-42°C might be due to volatilization of  $\text{NH}_3$ , as well as the partial closure of plastic bottles used. The slight increase in  $\text{NH}_3(\text{aq})$  levels over time in urea-treated compost at 22°C might be due to a slow degradation of organic nitrogen during incubation (Zeng et al. 2013). Subjected to the same urea treatment, there were no significant difference in the different temperatures (22, 32 and 42°C), but concentrations of  $\text{NH}_3$  varied widely. Indeed, small variations in pH can result in highly different  $\text{NH}_3$  concentrations, especially for a combination of high temperature and slight alkalinity (Nordin, 2009). In this study, the experiment was performed to access inactivation kinetics in 3 days because this time corresponded to the peak dissociation of urea to ammonia in biosolids (Nordin, 2009). The elevated level of pH and ammonium after urea addition should show an effect of pathogens destruction.

During urea treatment of compost with different urea concentrations for 3 days, a slight log reduction (1.1-2.1 log reduction) of microorganisms was observed at low urea concentration (urea 0-1%), indicating a low sanitizing effect. On the contrary, a significant reduction (2.1-3.1 log reduction) of microorganisms was observed with high urea concentration (urea 1.5-2%). Subjected to the same urea treatment (2%), the log reduction values of 1.2 and 2.1 log-reduction at temperatures 32 and 42°C, respectively, were significantly higher than that of 0.8 log-reduction at 22°C. However, this reduction of microorganisms increased with



temperature. For all microorganisms tested the log reduction of microorganisms increased with urea concentration and temperature. As a result, the reduction of microorganisms was positively correlated to the urea concentration and temperature. The sanitizing effectiveness of urea treatment of compost with the increase of urea concentration and temperature was confirmed by results obtained by Nordin et al. (2009) in human feces, by Vinnerås et al., (2007) in manure, and by Fidjeland et al., (2013) in sludge.

The inactivation of microorganisms with increasing urea concentration and temperature are well defined. The reduction of microorganisms in compost after urea addition is due to the presence of alkaline pH and ammonia in the compost. Indeed, the addition of urea in compost is converted to ammonia and carbon dioxide by the enzyme urease secreted by fecal bacteria present in the compost, and thus increases the pH. The ammonia is microbiocidal for microorganisms and responsible for their destruction during the urea treatment. Previous studies have shown the effects of alkaline pH and ammonia on pathogens destruction in fecal material (Pecson et al., 2007; Nordin et al., 2009; Katakam et al., 2014). Though the exact mechanism of action is not known, ammonia (in  $\text{NH}_3$  form) has been shown to have toxic effect on many microorganisms (Pecson et al., 2007; Bolton et al., 2013). The effects of alkaline pH are mainly the inactivation of protein membrane or the inactivation of the DNA/RNA strand (Sossou et al., 2014b). Besides, as a small, uncharged molecule, ammonia can cross the bacterial membrane and cause damage to the cell either by causing rapid alkalinization of the cytoplasm or through a decrease in intracellular  $\text{K}^+$  concentration (Park and Diez-Gonzalez, 2003).

As expected for each microorganism tested (*E. coli*, *Enterococcus* and *A. eggs*), the maximum inactivation rate constant was significantly low (0.82; 0.39; 0.34  $\text{h}^{-1}$ , respectively) at low urea concentration (0-1%) but high (1.55; 0.84; 0.73  $\text{h}^{-1}$ , respectively) at high urea concentration (1.5-2%). So, urea treatment at above 1.5% urea concentration showed a rapid inactivation of microorganisms than below 1% urea concentration. The reduction of indicator microorganisms during urea treatment is due to the urea addition which increases the pH and the  $\text{NH}_3$  concentration toxic for microbial cells. In the untreated compost (0%), the pH was critical for the formation of  $\text{NH}_3$  from the total ammonia and resulted in inactivation rate constant somewhat low. Therefore, the number of microorganisms detected in urea-treated compost declined more rapidly in compost treated with a high urea concentration than a low urea concentration. Subjected to the same urea treatment (2%), the inactivation rate constant was significantly high at temperatures 32 and 42°C and low at temperature 22°C (0.8 log-reduction). However, the inactivation rate constant increased with increase temperature and free ammonium. Though there was a large increase in  $\text{NH}_3(\text{aq})$  levels in urea-treated compost, the levels were apparently too low to inactivate the microorganisms at 22°C. This indicates that temperature was the main contributing factor to microbial destruction, whereas addition of urea helped increase  $\text{NH}_3(\text{aq})$  concentrations and thereby further increased the inactivation rate constant. Therefore, the inactivation rate of microorganisms was positively correlated to the urea concentration and incubation temperature (Ottoson et al., 2008). The present results confirm earlier studies that the increased of pH,  $\text{NH}_3(\text{aq})$  concentration and temperature may

increase the inactivation of indicator microorganisms (Pecson et al., 2007; Nordin et al., 2009; Katakam et al., 2014).

The die-off time is usually expressed as a decimal decay (T90) or as the time after which organisms are no longer detectable. This maximum survival time of *E. coli*, *Enterococcus* and *A. eggs* during urea treatment at low urea concentration (0-1%) were longer than that of higher concentration (1.5-2%). For example, the decimal value of *E. coli* was reduced from 7.6-3.7 days with 0-1% urea to 2.5-2.1 days with 1.5-2% at temperature 32°C. With the same urea concentration (2%), the decimal value of *E. coli* was reduced from 7.1 days at 22°C to 0.9 days at 42°C. The effective significant difference of *kmax* and T90 values was observed between high urea treated compost (1.5-2%) and low urea treated compost (0-1%). For all microorganisms tested, the *kmax* was reduced while T90 values increased with temperature decrease. The *kmax* and T90 values obtained in this study with urea treatment of compost are similar to those obtained by Nordin et al. (2009) in feces and Fidjeland et al., (2013) in sludge. These results demonstrated the positive effects of urea treatment on microbial inactivation. However the urea concentrations and the incubation temperatures, the urea treatment in this study was not effective for reducing all the microorganisms' population in the compost. More concentrations of urea were not tested in this study, because pH above 12 inhibits urease from fecal bacteria, thus unfavorable for urea degradation (Nordin, 2009).

Comparing the log reduction, the maximum inactivation rate constants (*kmax*) and the decimal decay (T90) values, *E. coli* was much more sensitive to urea treatment than *Enterococcus* and *A. eggs*. *Enterococcus* was studied here as an indicator of bacterial reduction but persisted longer in the urea-treated compost than *E. coli*. This confirms findings by Allievi et al. (1994) who studied *Enterococcus* spp. and total coliforms in sludge alkalized with aqueous ammonia. Using fecal enterococci as an indicator of bacterial survival in ammonia treatment will therefore lead to an overestimation of the risk associated with reuse of compost. As gram positive cocci (with lower cell-permeability as well as surface-to-volume ratio), they are probably less susceptible to ammonia than gram-negative rods. Vinnerås et al., (2003) also reported that, the inactivation of *Enterococcus* was somewhat slower. In the same way, *A. eggs* were the most persistent of organisms tested and showed little reduction in urea-treated compost. Helminth eggs are well-known for their high resistance to environmental stress because they may survive for years in agricultural matrices (WHO, 2006). The resistance of *A. eggs* might be due to the structural characteristics of the egg shells. Indeed, the *A. egg* shell contains some surrounding layers with special arrangement of chemical compounds inside the membrane layers. This may make it more tolerant and resistant to other unfavorable conditions (e.g. high NH<sub>3</sub>(aq) levels) compared to bacteria (Katakam et al., 2014).

The present results confirm earlier studies that the increased NH<sub>3</sub>(aq) concentration and temperature may increase the inactivation of microorganisms (Pecson et al., 2007; Nordin et al., 2009). Although the increase of pH and ammonia concentration increases the inactivation of pathogens (Pecson et al. 2007), Pecson et al. (2007) stated that pH effects are not significant. The authors have also reported that pH influence cannot be separated from

ammonia concentration and temperature. The effects of temperature may be dominant, because responsible for the dissociation level of urea added. However, the inactivation of microorganisms can also be influenced by other factors such as fecal material (compost) characteristics, volatile fatty acids, protein, fats, and carbohydrates. The impacts of these other factors in inactivation kinetics are yet unclear (Popat et al. 2010). Permeability of microbial cell increases greatly at temperatures increased (Rajagopal et al., 2013) and the faster inactivation at high temperatures (>32°C) might be due to increased permeability of cells. Slower inactivation at lower temperature (22°C) might be due to prolonged time needed to increase the permeability of the cells to  $\text{NH}_3(\text{aq})$ .

Urea is a low risk chemical that is easy to handle. Active disinfection will not start until it is added to a material containing the enzyme urease. For application of the method, the most important is that a closed treatment is performed otherwise unwanted emissions of ammonia into the environment take place leading to decrease of treatment efficiency. At the present small-scale experiment, ammonia-based sanitation is practiced for compost from composting toilet, because no mixing is required, as the diffusion of ammonia is sufficiently fast to be evenly distributed in the compost (Vinnerås et al. 2009). But in a large-scale one, initial mixing may be necessary due to no movement of compost. However, as enzymatic degradation of urea does not take place immediately, the technique allows for initial mixing without ammonia losses. The addition of urea increases the fertilizer value and as long as the ammonia produced is retained in the compost as  $\text{NH}_3$ , it will inhibit microbial activity and bacterial regrowth.

Finally, quantification of bacteria in this study was enumerated using a conventional culture method. Although, some reports indicated the correlation between culture and direct count method (Viau and Peccia 2009), there is still need to validate the culture method in relation to the viable cells and not cultivable cells. In the same way, Collick et al. (2007) reported about parasite eggs that, to ascertain their viability in stress conditions, count by larvae development is needed in comparison with the direct microscopy counting used in this study.

#### **6.4. CONCLUSION**

This study was investigated to evaluate the survival of indicator microorganisms in compost during urea treatment at different concentrations and temperatures for sanitizing compost from composting toilet. The results showed that urea addition to compost enhanced inactivation of microorganisms. The decline number of *E. coli* and *Enterococcus* followed a linear reduction, while that of *A. eggs* followed a linear reduction plus shoulder. The inactivation rate constants of all microorganisms tested were positively correlated to the increase of  $\text{NH}_3$  (aq) concentration and temperature. The relationships between inactivation rate of microorganism, ammonia through urea concentration and temperature were established. Therefore, the best decimal decay of *E. coli* and *Enterococcus* and *A. eggs* occurred with 2% w/w urea concentration at 42°C within 6.5, 7.5 and 8.4 days, respectively. *E. coli* was the most sensitive microorganism to urea treatment while *Enterococcus* and *A.*

eggs showed resistance to it, especially at lower temperatures. Urea treatment has proved to be an efficient option for safe use of compost.

## 6.5. REFERENCES

- Allievi, L., Colombi, A., Calcaterra E. and Ferrari, A. (1994) Inactivation of fecal bacteria in sewage sludge by alkaline treatment. *Bioresource Technology*, 49, 25-30.
- Bolton, D., Ivory, C. and McDowell, D. (2013) The effect of urea and ammonia treatments on the survival of *Salmonella* spp. and *Yersinia enterocolitica* in pig slurry. *Journal of Applied Microbiology*, 114, 134-140.
- Collick, A. S., Inglis, S., Wright, P., Steenhuis, TS and Bowman, DD (2007) Inactivation of *Ascaris suum* in a biodrying compost system. *Journal of Environmental Quality*, 36, 1528-1533.
- Emerson, K., Russo, R., Lund, R. and Thurston, R. (1975) Aqueous ammonia equilibrium calculations: effects of pH and temperature. *Journal of the Fisheries Research Board of Canada*, 32, 2379-2383.
- Fidjeland, J., Lalander, C., Jönsson, H. and Vinnerås, B. (2013) Ammonia sanitization of sewage sludge using urea. *Water Science and Technology*, 68, 1866-1872.
- Geeraerd, A. H., Valdramidis, V. P. and Van Impe, J. F. (2005) GInaFiT, a freeware tool to assess non-log-linear microbial survivor curves. *International Journal of Food Microbiology*, 102, 95-105.
- Jiménez, B., Drechsel, P., Kone, D., Bahri, A., Raschid-Sally, L. and Qadir, M. (2009) Wastewater, sludge and excreta use in developing countries: An overview', in P. Drechsel, C.A. Scott, L. Raschid-Sally, M. Redwood and A. Bahri (eds.), *Wastewater Irrigation and Health: Assessing and Mitigating Risk in Lowincome Countries*, Earthscan, London, UK.
- Katakam, K. K., Mejer, H., Dalsgaard, A., Kyvsgaard, N. C. and Thamsborg, S. M. (2014) Survival of *Ascaris suum* and *Ascaridia galli* eggs in liquid manure at different ammonia concentrations and temperatures. *Veterinary Parasitology*, 204, 249-257.
- Lang, N. L. and Smith, S. R. (2008) Time and temperature inactivation kinetics of enteric bacteria relevant to sewage sludge treatment processes for agricultural use. *Water Research*, 42, 2229-2241.
- Lasaridi, K., Protopapa, I., Kotsou, M., Pilidis, G., Manios, T. and Kyriacou, A. (2006) Quality assessment of composts in the Greek market: The need for standards and quality assurance. *Journal of Environmental Management*, 80, 58-65.

- Lopez Zavala, M. A., Funamizu, N. and Takakuwa, T. (2004) Temperature effect on aerobic biodegradation of feces using sawdust as a matrix. *Water Research*, 38, 2406-2416.
- Magri, M. E., Philippi, L. S. and Vinnerås, B. (2013) Inactivation of pathogens in feces by desiccation and urea treatment for application in urine-diverting dry toilets. *Applied and Environmental Microbiology*, 79, 2156-2163.
- Mnkeni, P. N. S. and Austin, L. M. (2009) Fertilizer value of human manure from pilot urine-diversion toilets. *Water SA*, 35, 133-138.
- Mobley, H. and Hausinger, R. (1989) Microbial ureases: significance, regulation, and molecular characterization. *Microbiological Reviews* 53: 85-108.
- Nordin, A., Nyberg, K. and Vinneras, B. (2009) Inactivation of *Ascaris* eggs in source-separated urine and feces by ammonia at ambient temperatures. *Applied and Environmental Microbiology*, 75, 662–667.
- Ottoson, J., Nordin, A., Von Rosen, D. and Vinnerås, B. (2008) *Salmonella* reduction in manure by the addition of urea and ammonia. *Bioresource Technology*, 99, 1610–1615.
- Park, G. W. and Diez-Gonzalez, F. (2003) Utilization of carbonate and ammonia-based treatments to eliminate *Escherichia coli* O157:H7 and *Salmonella Typhimurium* DT104 from cattle manure. *Journal of Applied Microbiology*, 94, 675–685.
- Pecson, B. M., Barrios, J. A., Jimenez, B. E. and Nelson, K. L. (2007) The effects of temperature, pH, and ammonia concentration on the inactivation of *Ascaris* eggs in sewage sludge. *Water Research*, 41, 2893–2902.
- Philippe, F., Cabaraux, J. and Nicks, B. (2011) Ammonia emissions from pig houses: influencing factors and mitigation techniques. *Agriculture, Ecosystems and Environment*, 141, 245–260.
- Popat, S. C., Yates, M. V. and Deshusses, M. A. (2010) Kinetics of inactivation of indicator pathogens during thermophilic anaerobic digestion. *Water Research*, 44, 5965-5972.
- Rajagopal, R., Masse, D. I. and Singh, G. (2013) A critical review on inhibition of anaerobic digestion process by excess ammonia. *Bioresource Technology*, 143, 632-641.
- Sossou, S. K., Hijikata, N., Sou, M., Tezuka, R., Maiga, A. H. and Funamizu, N. (2014b). Inactivation mechanisms of pathogenic bacteria in several matrixes during the composting process in a composting toilet. *Environmental Technology*, 35, 674-680.
- Sossou, S. K., Sou/Dakoure, M., Hijikata, N., Quenum, A., Maiga, A. H. and Funamizu, N. (2014a) Removal and deactivation of intestinal parasites in aerobic mesophilic composting reactor for urine diverting composting toilet. *Compost Science and Utilization*, 22, 242-252.

- Viau, E. and Peccia, J. (2009). Evaluation of the enterococci indicator in biosolids using culture-based and quantitative PCR assays. *Water Research*, 43, 4878-4887.
- Vinnerås, B., Björklund, A. and Jönsson H. (2003) Thermal composting of fecal matter as treatment and possible disinfection method-laboratory-scale and pilot-scale studies, *Bioresource Technology*. 88, 47-54.
- Vinnerås, B. (2007) Comparison of composting, storage and urea treatment for sanitizing of faecal matter and manure. *Bioresource Technology*, 98, 3317-3321.
- WHO (2006) Guidelines for the Safe Use of Wastewater, Excreta and Greywater: Policy and regulatory aspects, World Health Organization (Ed.), Vol. 4, Geneva, Switzerland.
- WHO/UNICEF (2013). Joint Monitoring Program for Water Supply and Sanitizing 2013. From WHO Geneva, Publications (2013). <http://www.wssinfo.org/>
- Zeng, Y, De Guardia, A, Ziebal, C, De Macedo, FJ and Dabert, P (2013) Impact of biodegradation of organic matters on ammonia oxidation in compost. *Bioresource Technology*, 136, 49-57.

## Chapter 7

### GENERAL CONCLUSIONS AND FUTURE STUDIES

This thesis study was investigated to assess the fate of intestinal parasites and pathogenic bacteria in the composting toilet. The results were as follow:

The removal and deactivation of intestinal parasites in composting toilet showed that, in composting process not only *Ascaris* as helminths eggs are a good indicator for the removal of parasites but either *Entamoeba* as protozoan cysts. As such finding should interest compost users that, in high concentration *Entamoeba* cysts could survived stronger than *Ascaris* eggs in the end-compost and may constitute a sanitary risk when used as agricultural fertilizer. Therefore care should be take when find pathogens protozoan in high concentration than pathogens helminths in feces for composting.

The inactivation mechanisms of pathogenic bacteria during composting process showed that, composting matrixes and composting process did not significantly affect inactivation rate of pathogenic bacteria but affected damaging part or function of the bacteria. As such result should be of interest to a broad readership including those interested by the choice of matrix and time process from the viewpoint of hygienic aspect in composting toilet.

The sanitizing effectiveness of solar heating as post-treatment on compost showed that, a solar box can provide a high and uniform temperature distribution during compost heating and proved to be an efficient option for safe use of compost. The fatal temperatures of pathogens in compost can be reached in a short time by using a solar box. As such result could be interest to a broad readership including those interested by the type of thermal treatment for removal pathogens in compost a short time from the viewpoint of hygienic risk.

## APPENDIX

### APPENDIX 1. Parasitological analysis (US EPA protocol (1999) modified by Schwartzbrod (2003)

- ✓ Homogenize the extract compost sample for 30 seconds using a blender with 22,000 rpm (the blended sample should be equivalent to 10 g TS ; liquid composts may be blended undiluted ,while dewatered or dried composts should be resuspended in tap water to give a volume of approx.400 ml).
- ✓ Screen the compost through a 160 µm screen with 2 l of water per sample
- ✓ Collect the filtrate in the same 2 l contained. Let it settle overnight or for 3 hours (for water, start at this stage). Suck up as much of the supernatant as possible and place the sediment in a 450 ml centrifugal flask
- ✓ Rinse the 2-litre contained 2 to 3 times
- ✓ Centrifuge at 400 g for 3 min. (1450 rpm)
- ✓ Pour the supernatant and resuspend the deposit of 150 ml with ZnSO<sub>4</sub> Of 1.3 density
- ✓ Homogenize with a spatula
- ✓ Centrifuge at 400 g for 3 min. (1050 rpm)
- ✓ Pour the ZnSO<sub>4</sub> supernatant in a 2 litres flasks and dilute it with at least 1 l of water. Let it settle for 3 hours. Suck up as much of the supernatant as possible and resuspend the deposit by shaking, empty it in 2 tubes of 50 ml and clean 2 to 3times with deionized water place the rinsing liquid in the 50 ml tubes
- ✓ Centrifuges at 480 g for 3 min.(1600 rpm)
- ✓ Regroup the deposits in a tube of 50 ml and centrifuge at 480 g for 3 minutes
- ✓ Resuspend the deposits in a 15 ml acid /alcohol (H<sub>2</sub>SO<sub>4</sub>+C<sub>2</sub>H<sub>5</sub>OH) Or 5 ml acetic acid solution
- ✓ And add 10 ml ethyl ether or 5 ml ethyl acetate
- ✓ Shake and open occasionally to let out the gas
- ✓ Centrifuge at 660 g for 3 min.
- ✓ Suck up as much supernatant as possible to leave less than 1 ml of liquid
- ✓ Observe and read at microscope
- ✓ For quantification of helminths eggs , use the formula

$$\text{Number of helminth eggs/liter} = (\Sigma \text{helminth eggs present}/V) \times k$$

Where, V = volume of initial sample compost

K = constant related to the performance of the method (k = 1.42)

Correspond to the weight of dry compost diluted