



(19) **United States**  
(12) **Patent Application Publication**  
**Foret**

(10) **Pub. No.: US 2009/0206721 A1**  
(43) **Pub. Date: Aug. 20, 2009**

(54) **SYSTEM, METHOD AND APPARATUS FOR COUPLING A SOLID OXIDE HIGH TEMPERATURE ELECTROLYSIS GLOW DISCHARGE CELL TO A PLASMA ARC TORCH**

**Publication Classification**

(51) **Int. Cl.**  
*H01J 17/26* (2006.01)  
(52) **U.S. Cl.** ..... 313/231.01  
(57) **ABSTRACT**

(75) Inventor: **Todd Foret**, Lafayette, LA (US)

Correspondence Address:  
**CHALKER FLORES, LLP**  
**2711 LBJ FRWY, Suite 1036**  
**DALLAS, TX 75234 (US)**

(73) Assignee: **Foret Plasma Labs, LLC**, The Woodlands, TX (US)

(21) Appl. No.: **12/371,575**

(22) Filed: **Feb. 13, 2009**

**Related U.S. Application Data**

(63) Continuation-in-part of application No. 12/370,591, filed on Feb. 12, 2009, Continuation-in-part of application No. 12/288,170, filed on Oct. 17, 2008.

(60) Provisional application No. 61/028,386, filed on Feb. 13, 2008, provisional application No. 61/027,879, filed on Feb. 12, 2008.

The present invention provides a glow discharge cell comprising an electrically conductive cylindrical vessel having a first end and a second end, and at least one inlet and one outlet; a hollow electrode aligned with a longitudinal axis of the cylindrical vessel and extending at least from the first end to the second end of the cylindrical vessel, wherein the hollow electrode has an inlet and an outlet; a first insulator that seals the first end of the cylindrical vessel around the hollow electrode and maintains a substantially equidistant gap between the cylindrical vessel and the hollow electrode; a second insulator that seals the second end of the cylindrical vessel around the hollow electrode and maintains the substantially equidistant gap between the cylindrical vessel and the hollow electrode; a non-conductive granular material disposed within the gap, wherein the non-conductive granular material (a) allows an electrically conductive fluid to flow between the cylindrical vessel and the hollow electrode, and (b) prevents electrical arcing between the cylindrical vessel and the hollow electrode during a electric glow discharge; and wherein the electric glow discharge is created whenever: (a) the glow discharge cell is connected to an electrical power source such that the cylindrical vessel is an anode and the hollow electrode is a cathode, and (b) the electrically conductive fluid is introduced into the gap.

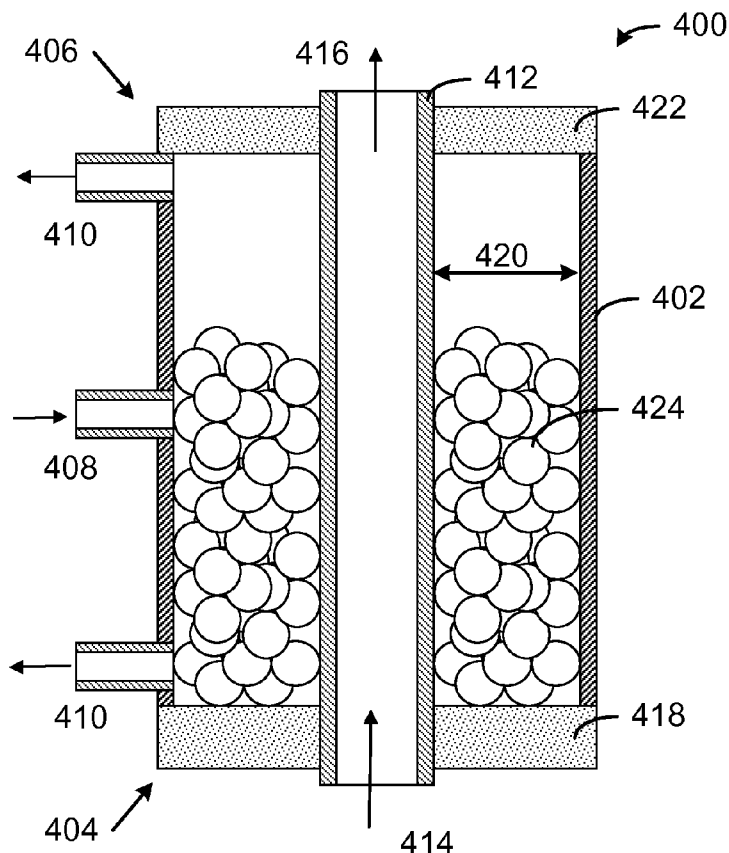

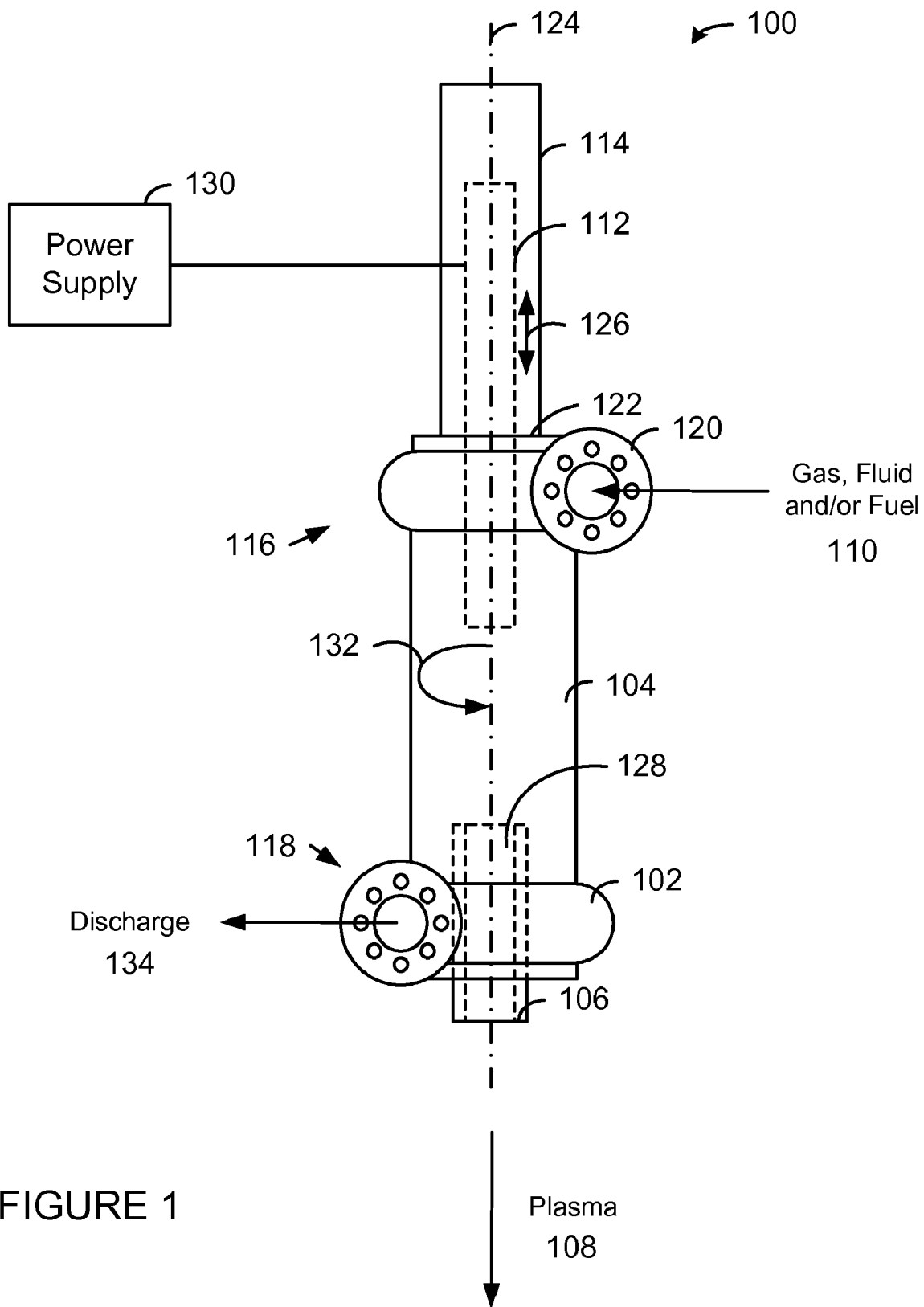

FIGURE 1

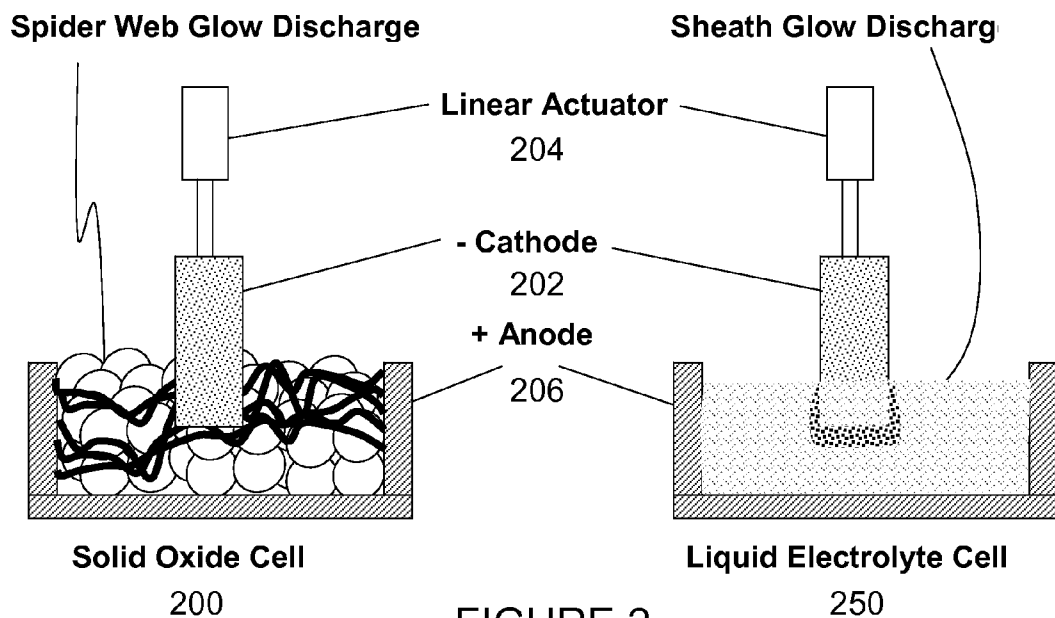

FIGURE 2

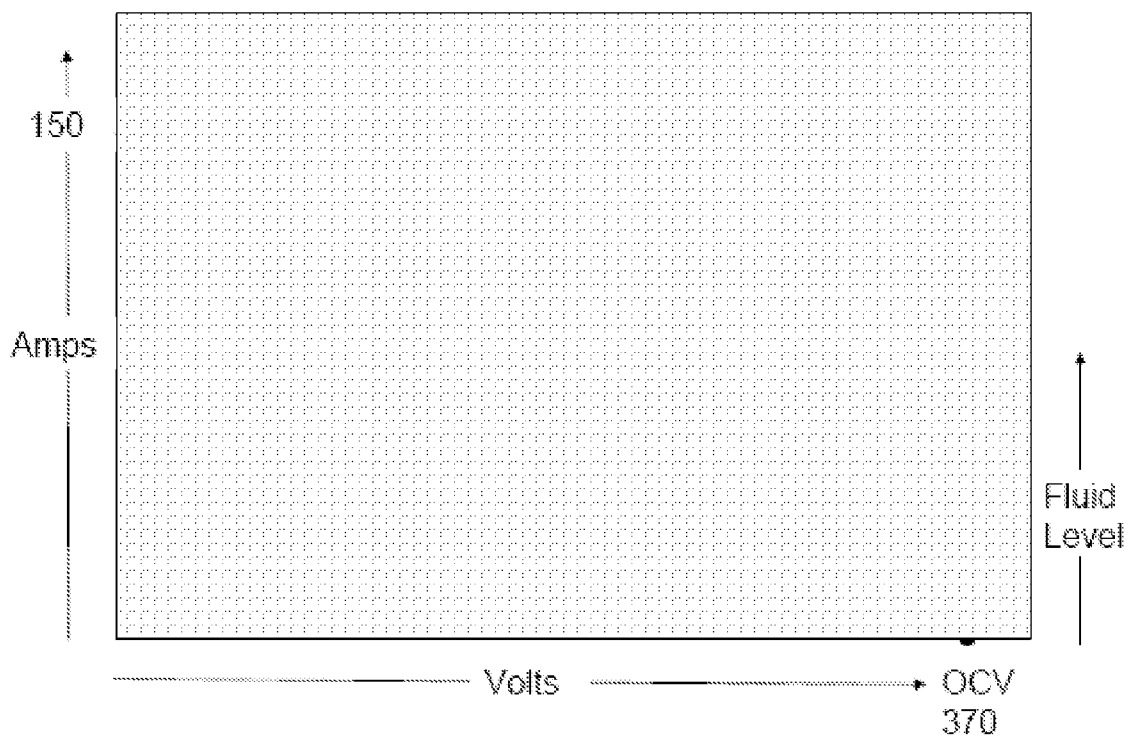

FIGURE 3

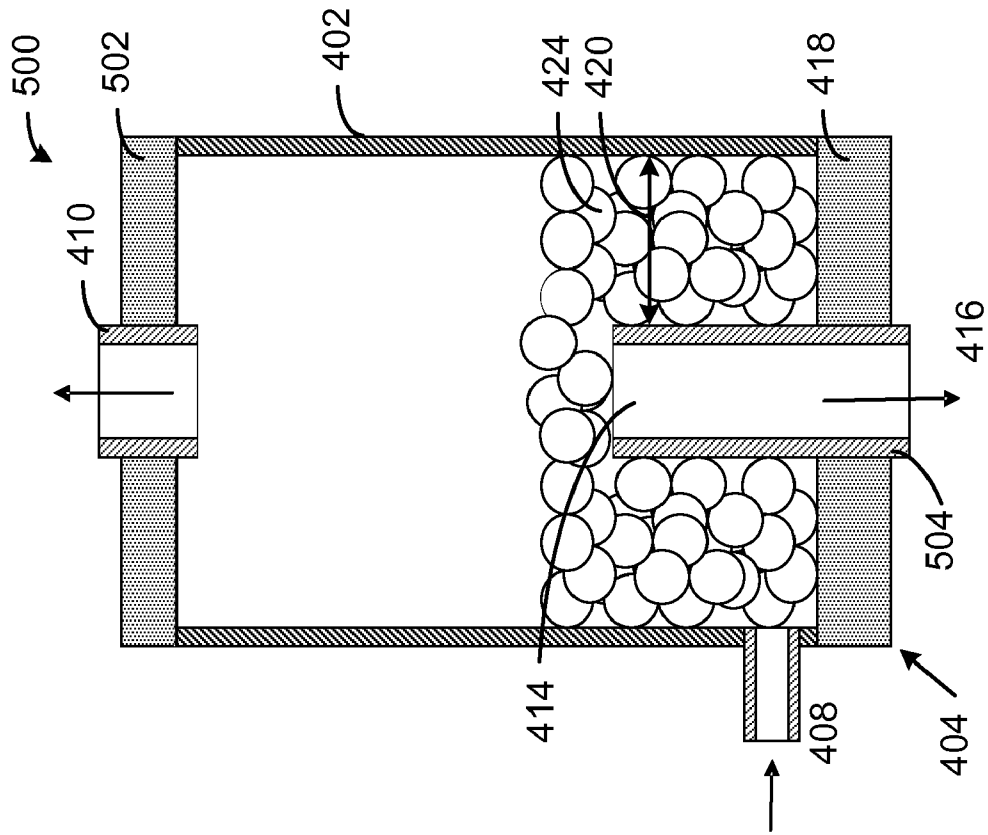

FIGURE 5

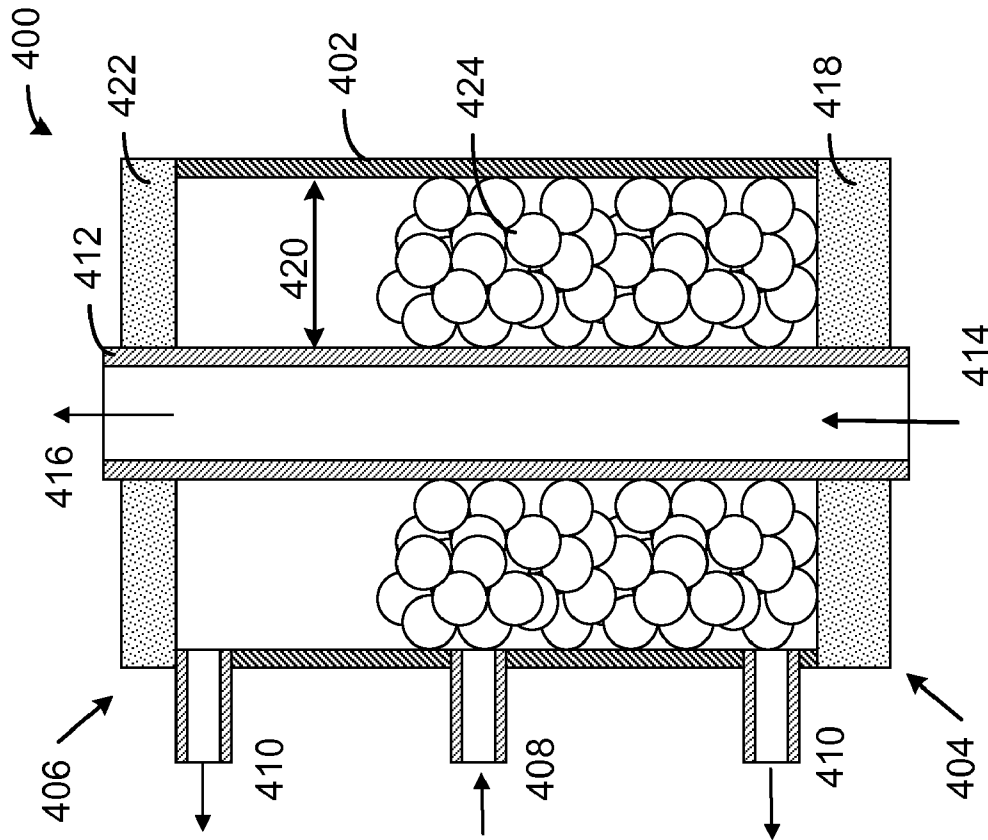

FIGURE 4

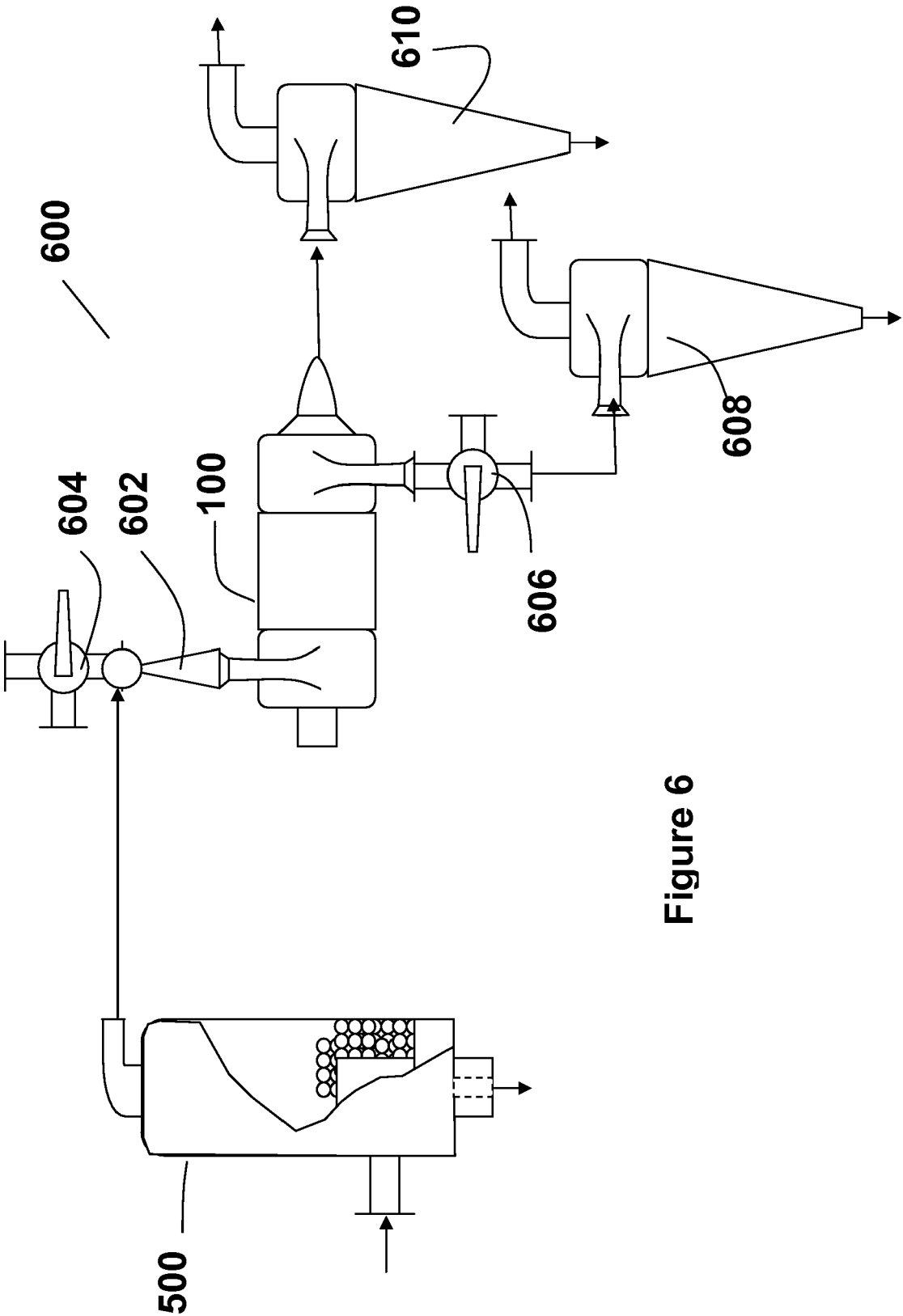

Figure 6

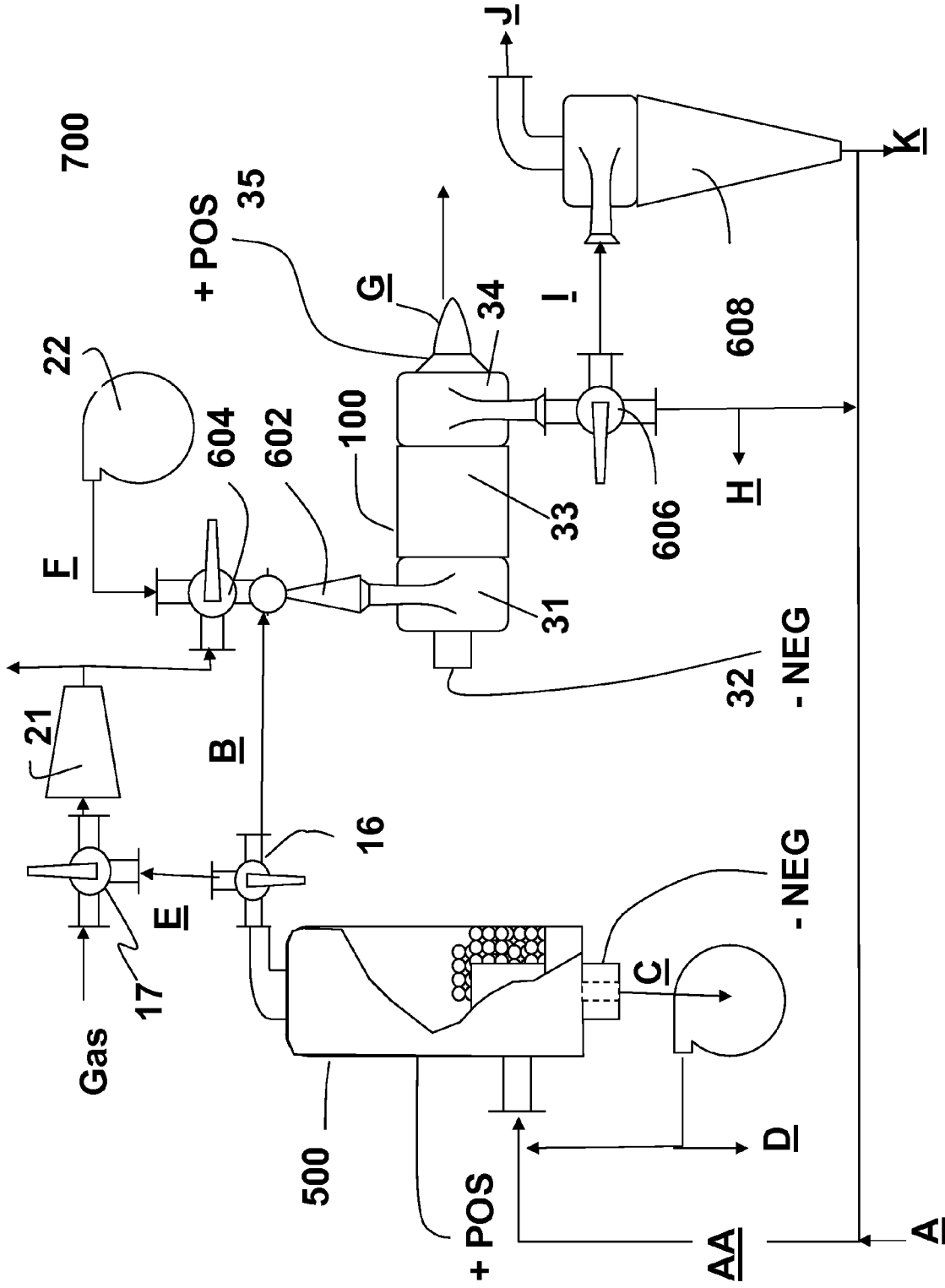

Figure 7

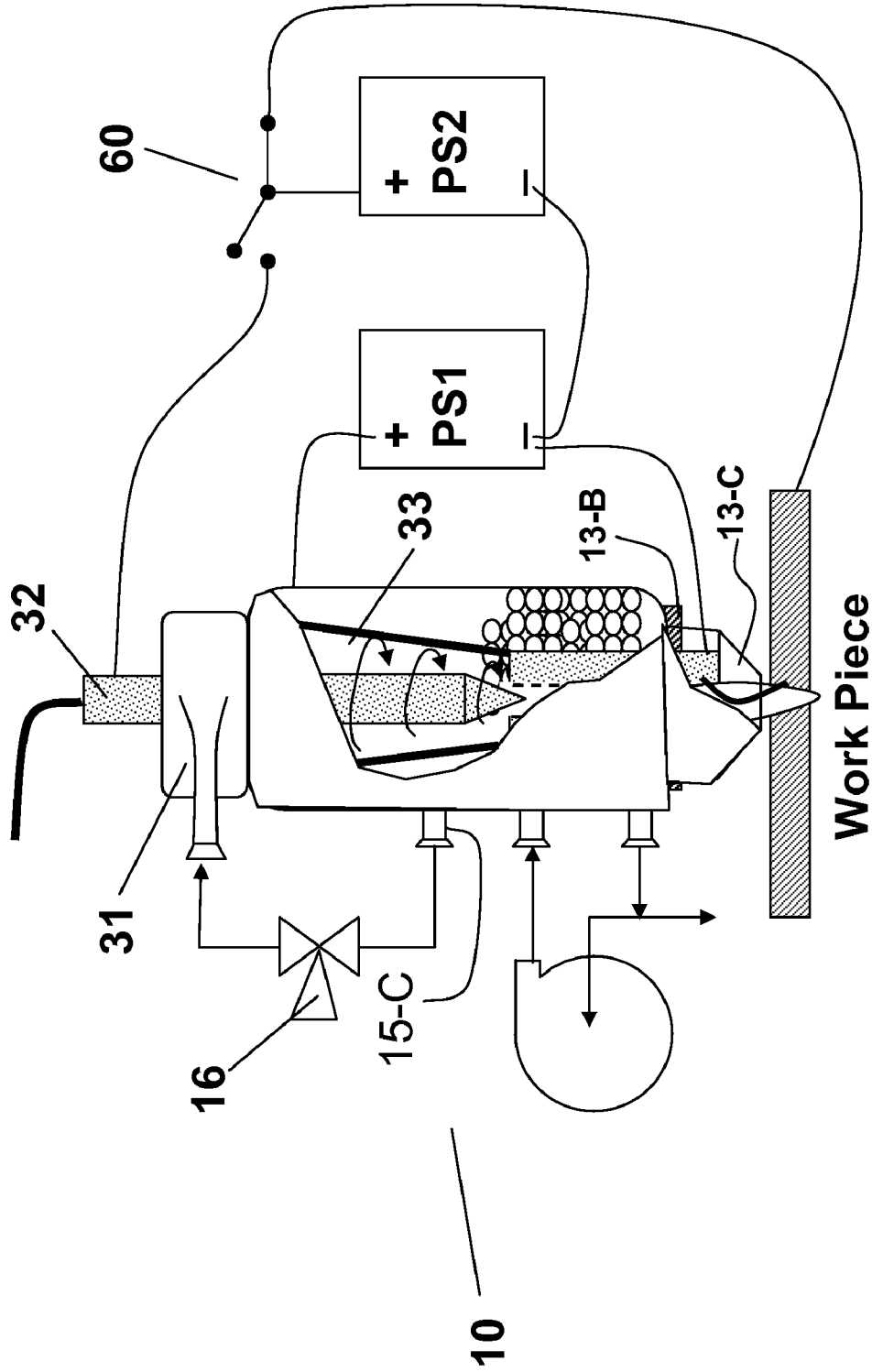

Figure 8

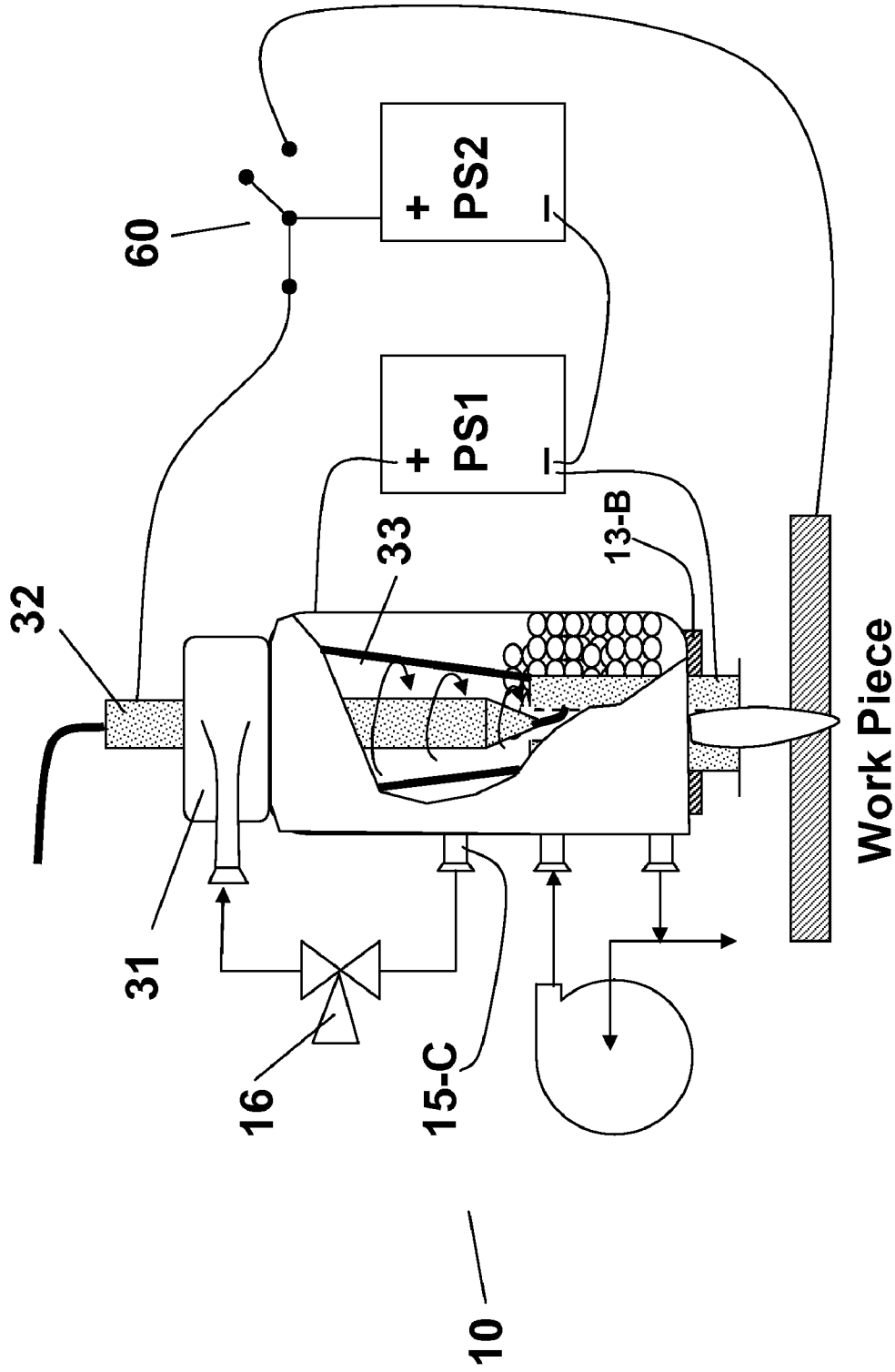

Figure 9





Fig. 10 - Tailings Pond Water Results

dgg rev 11-14-08

**FILTRATE:**

Sample	Date	pH	SG	Cr	%N	ppm F	%Fe2O3	%SO4	ppm NH3	%P2O5	%Si	%MgO	%Al2O3	%CaO	%Na	%K	As	Cd	Co	Cu	Mo	Ni	
A Tailings Pond Water	30-Oct	1.4	1.0468	4.0	0.14	7,921	0.01	0.40	1,310	2.17	0.06	0.04	0.01	0.25	0.25	0.03	7.0	0.7	0.0	3.5	1.0	3.0	
1 HI Temper	6-Nov	2.3	1.0300	0.0	0.01	103	0.00	0.01	487	0.00	0.01	0.00	0.00	0.05	0.05	0.01	2.3	0.0	0.0	1.5	0.0	0.0	
2 HI Temper Arc Whirl Arc Whirl, plasma on	6-Nov	1.7	1.0300	18.3	0.01	3,480	0.02	0.24	708	8.88	0.03	0.02	0.01	0.17	0.14	0.02	5.5	0.0	0.0	7.9	0.2	14.0	
3 HI Temper Air Arc Whirl	6-Nov	1.5	1.0400	71.4	0.18	8,570	0.06	0.52	1,630	2.30	0.04	0.05	0.01	0.35	0.26	0.03	7.3	0.3	0.0	15.7	0.6	42.8	
4 Bottoms Off reactor	6-Nov	1.2	1.1600	667.3	0.15	14,400	0.76	1.39	4,340	8.72	0.03	0.16	0.02	0.86	0.24	0.04	12.4	4.1	4.0	15.3	7.0	356.7	
5 Bomb Gas, Arc on, plasma off	6-Nov																						

Insufficient sample recovered for analysis.

Cycles of concentration  
(COC Set 1)

167	1	2	51	3	3	4	1	4	2	3	1	1	2	6	400	4	7	120
55	2	0	19	2	2	1	0	3	0	2	1	1	1	3	30	2	3	84

**SOLIDS (Retained on Whatmann #40 filter paper):**

Sample	Date	gm, dry	%P2O5	%SO4	%MgO	%Al2O3	%Fe2O3	%CaO	%Na	%K	%Si	ppmN
A Tailings	30-Oct		3.30	3.35	0.06	0.45	0.09	3.56	0.44	0.05	0.08	14
1 HI Temper	6-Nov	2.7	0.0	0.2	0.02	0.02	1.09	0.2	0.22	0.02	0.02	0.0
2 HI Temper Arc Whirl Arc Whirl, plasma on	6-Nov	2.7	1.6	0.5	0.04	0.02	0.30	0.4	0.31	0.03	0.03	0.0
3 HI Temper Air Arc Whirl	6-Nov	4.0	2.5	0.7	0.04	0.10	0.83	1.0	0.22	0.04	0.04	0.0
4 Bottoms Off reactor	6-Nov	29.1	1.8	13.6	0.03	0.25	0.35	5.7	13.67	2.76	0.85	0.0
5 Bomb Gas, Arc on, plasma off	6-Nov											

Insufficient sample recovered for analysis.

Pb	Se	Mn	U	V	Zn	Ti	Appearance:
0.0	3.0	12.0	14.0	7.4	20.2	1.7	Colorless, slightly cloudy Settlable fines
0.0	3.4	0.0	0.0	0.0	1.6	0.0	Clear; yellowish or brownish
0.0	2.7	4.2	2.2	1.3	13.4	0.0	Clear; yellowish or brownish
0.0	2.0	18.6	12.0	5.4	49.6	13.7	Very light green
0.0	1.3	112.7	41.1	26.4	354.4	7.7	Dark green, with sediment

0	0	9	3	4	18	5
0	0	7	1	2	24	0

**SYSTEM, METHOD AND APPARATUS FOR  
COUPLING A SOLID OXIDE HIGH  
TEMPERATURE ELECTROLYSIS GLOW  
DISCHARGE CELL TO A PLASMA ARC  
TORCH**

FIELD OF THE INVENTION

**[0001]** The present invention relates generally to solid oxide electrolysis cells and plasma torches. More specifically, the present invention relates to a thin film solid oxide glow discharge direct current cell coupled to a direct current plasma torch which can be used as a transferred arc or non-transferred arc plasma torch, chemical reactor, reboiler, heater, concentrator, evaporator, coker, gasifier, combustor, thermal oxidizer, steam reformer or high temperature plasma electrolysis hydrogen generator.

PRIORITY CLAIM AND CROSS-REFERENCE  
TO RELATED APPLICATIONS

**[0002]** This patent application is: (a) a continuation-in-part application of U.S. patent application Ser. No. 12/288,170 filed on Oct. 16, 2008 and entitled "System, Method And Apparatus for Creating an Electric Glow Discharge", which is a non-provisional application of U.S. provisional patent application 60/980,443 filed on Oct. 16, 2007 and entitled "System, Method and Apparatus for Carbonizing Oil Shale with Electrolysis Plasma Well Screen"; (b) a continuation-in-part application of U.S. patent application Ser. No. 12/370,591 filed on Feb. 12, 2009 and entitled "System, Method and Apparatus for Lean Combustion with Plasma from an Electrical Arc", which is non-provisional patent application of U.S. provisional patent application Ser. No. 61/027,879 filed on Feb. 12, 2008 and entitled, "System, Method and Apparatus for Lean Combustion with Plasma from an Electrical Arc"; and (c) a non-provisional patent application of U.S. provisional patent application 61/028,386 filed on Feb. 13, 2008 and entitled "High Temperature Plasma Electrolysis Reactor Configured as an Evaporator, Filter, Heater or Torch." All of the foregoing applications are hereby incorporated by reference in their entirety.

BACKGROUND OF THE INVENTION

**[0003]** Glow discharge and plasma systems are becoming every more present with the emphasis on renewable fuels, pollution prevention, clean water and more efficient processing methods. Glow discharge is also referred to as electroplasma, plasma electrolysis and high temperature electrolysis. In liquid glow discharge systems a plasma sheath is formed around the cathode located within an electrolysis cell.

**[0004]** U.S. Pat. No. 6,228,266 issued to Shim, Soon Yong (Seoul, KR) titled, "Water treatment apparatus using plasma reactor and method thereof" discloses a water treatment apparatus using a plasma reactor and a method of water treatment. The apparatus includes a housing having a polluted water inlet and a polluted water outlet; a plurality of beads filled into the interior of the housing; a pair of electrodes, one of the

electrodes contacting with the bottom of the housing, another of the electrodes contacting an upper portion of the uppermost beads; and a pulse generator connected with the electrodes by a power cable for generating pulses.

**[0005]** The major drawback of Shim's '266 patent is the use of a pulse generator and utilizing extremely high voltages. For example, Shim discloses in the Field of the Invention the use of extremely dangerous high voltages ranging from 30 KW to 150 KV. Likewise, he further discloses "In more detail, a voltage of 20-150 KV is applied to the water film having the above-described thickness, forming a relatively high electric magnetic field. Therefore, plasmas are formed between the beads **5** in a web shape. The activated radicals such as O, H, O<sub>3</sub>, H<sub>2</sub>O<sub>2</sub>, UV, and e-aq are generated in the housing **2** by the generated plasmas. The thusly generated activated radicals are reacted with the pollutants contained in the polluted water."

**[0006]** In addition, Shim discloses, "Namely, when pulses are supplied to the electrodes **6** in the housing **2**, a web-like plasma having more than about 10 eV is generated. At this time, since the energy of 1 eV corresponds to the temperature of about 10,000° C., in theory, the plasma generated in the housing **2** has a temperature of more than about 100,000° C."

**[0007]** Finally, Shim claims, 1. A plasma reactor, comprising: a housing having a polluted water inlet, a polluted water outlet and an air inlet hole; a plurality of beads disposed in the interior of the housing, said beads being selected from the group consisting of a ferro dielectric material, a photocatalytic acryl material, a photocatalytic polyethylene material, a photocatalytic nylon material, and a photocatalytic glass material; a pair of electrodes, one of said electrodes contacting the bottom of the housing, another of said electrodes contacting an upper portion of the uppermost beads; and a pulse generator connected with the electrodes."

**[0008]** Shim's '266 plasma reactor has several major drawbacks. For it must use a high voltage pulsed generator, a plurality of various beads and it must be operated such that the reactor is full from top to bottom. Likewise, Shim's plasma reactor is not designed for separating a gas from the bulk liquid, nor can it recover heat. Shim makes absolutely no claim to a method for generating hydrogen. In fact, the addition of air to his plasma reactor completely defeats the sole purpose of current research for generating hydrogen via electrolysis or plasma or a combination of both. In the instant any hydrogen is generated within the '266 plasma reactor, the addition of air will cause the hydrogen to react with oxygen and form water. Also, Shim makes absolutely no mention for any means for generating heat by cooling the cathode. Likewise, he does not disclose nor mention the ability to coke organics unto the beads, nor the ability to reboil and concentrate spent acids such as tailing pond water from phosphoric acid plants nor concentrate black liquor from fiber production and/or pulp and paper mills. In particular, he does not disclose nor teach any method for concentrating black liquor nor recovering caustic and sulfides from black liquor with his '266 plasma reactor.

**[0009]** The following is a list of prior art similar to Shim's '266 patent.

0481979		September, 1892	Stanley	
0501732		July, 1893	Roeske	210/748
3798784	PROCESS AND APPARATUS FOR THE TREATMENT OF MOIST MATERIALS	March, 1974	Kovats et al.	210/748

-continued

4265747	Disinfection and purification of fluids using focused laser radiation	May, 1981	Copa et al.	
4624765	Separation of dispersed liquid phase from continuous fluid phase	November, 1986	Cerkanowicz et al.	210/748
5019268	Method and apparatus for purifying waste water	May, 1991	Rogalla	210/617
5048404	High pulsed voltage systems for extending the shelf life of pumpable food products	September, 1991	Bushnell	
5326530	Energy-efficient electromagnetic elimination of noxious biological organisms	July, 1994	Bridges	
5348629	Method and apparatus for electrolytic processing of materials	September, 1994	Khudenko	204/130
5368724	Apparatus for treating a confined liquid by means of a pulse electrical discharge	November, 1994	Ayers et al.	210/110
5655210	Corona source for producing corona discharge and fluid waste treatment with corona discharge	August, 1997	Gregoire	
5746984	Exhaust system with emissions storage device and plasma reactor	May, 1998	Hoard	
5879555	Electrochemical treatment of materials	March, 1999	Khudenko	210/615
5893979	Method for dewatering previously-dewatered municipal waste-water sludges using high electrical voltage	April, 1999	Held	210/748
6007681	Apparatus and method for treating exhaust gas and pulse generator used therefor	December, 1999	Kawamura et al.	

**[0010]** Shim's '266 patent does not disclose, teach nor claim any method, system or apparatus for a solid oxide electrolysis cell coupled to a plasma arc torch. In fact, Shim's '266 patent does not distinguish between glow discharge and plasma produced from an electrical arc. Finally, Shim's '266 patent teaches the use of nylon and other plastic type beads. In fact, he claims the plasma reactor must contain three types of plastics: a photocatalytic acryl material, a photocatalytic polyethylene material, a photocatalytic nylon material. In contradiction, he teaches, "At this time, since the energy of 1 eV corresponds to the temperature of about 10,000° C., in theory, the plasma generated in the housing 2 has a temperature of more than about 100,000° C."

**[0011]** Quite simply, the downfall of Shim's patent is that the plasma will destroy the organic beads, converting them to carbon and or carbon dioxide and thus preventing the invention from working as disclosed. In fact, the inventor of the present invention will clearly show and demonstrate why polymers will not survive within a glow discharge type plasma reactor.

**[0012]** Plasma arc torches are commonly used by fabricators, machine shops, welders and semi-conductor plants for cutting, gouging, welding, plasma spraying coatings and manufacturing wafers. The plasma torch is operated in one of two modes—transferred arc or non-transferred arc. The most common torch found in many welding shops in the transferred arc plasma torch. It is operated very similar to a DC welder in that a grounding clamp is attached to a workpiece. The operator, usually a welder, depresses a trigger on the plasma torch handle which forms a pilot arc between a cen-

trally located cathode and an anode nozzle. When the operator brings the plasma torch pilot arc close to the workpiece the arc is transferred from the anode nozzle via the electrically conductive plasma to the workpiece. Hence the name transferred arc.

**[0013]** The non-transferred arc plasma torch retains the arc within the torch. Quite simply the arc remains attached to the anode nozzle. This requires cooling the anode. Common non-transferred arc plasma torches have a heat rejection rate of 30%. Thus, 30% of the total torch power is rejected as heat.

**[0014]** A major drawback in using plasma torches is the cost of inert gases such as argon and hydrogen. There have been several attempts for forming the working or plasma gas within the torch itself by using rejected heat from the electrodes to generate steam from water. The objective is to increase the total efficiency of the torch as well as reduce plasma gas cost. However, there is not a single working example that can run continuous duty. The Multiplaz torch is a small hand held torch that must be manually refilled with water. The technology behind the Multiplaz 2500 is patented worldwide.

**[0015]** Russian patents: N 2040124, N 2071190, N 2103129, N 2072640, N 2111098, N 2112635. European patents N 0919317 A1. American patents: N 6087616, N 6156994. Australian patents N 736916.

**[0016]** Also, the device is covered by international patent applications N RU 96-00188 and N RU 98-00040 in Austria, Belgium, Switzerland, Germany, Denmark, Spain, Finland, France, Great Britain, Greece, Ireland, Italy, Liechtenstein, Luxemburg, Monaco, Nederland, Portugal, Sweden, Korea, USA, Australia, Brasilia, Canada, Israel.

3567898	PLASMA ARC CUTTING TORCH	March, 1971	Fein	219/121.39
3830428	PLASMA TORCHES	August, 1974	Dyos	219/121.5
4311897	Plasma arc torch and nozzle assembly	January, 1982	Yerushalmy	219/121.5
4531043	Method of and apparatus for stabilization of low-temperature plasma of an arc burner	July, 1985	Zverina et al.	219/121.5
5609777	Electric-arc plasma steam torch	March, 1997	Apenuvich et al.	219/121.48

-continued

---

5660743	Plasma arc torch having water injection nozzle assembly	August, 1997	Nemchinsky 219/121.5
---------	---	--------------	----------------------

---

**[0017]** The inventor of the present invention purchased a first generation multiplaz torch. It worked until the internal glass insulator cracked and then short circuited the cathode to the anode. Next, he purchased two multiplaz 2500's. One torch never stayed lit for longer than 15 seconds. The other torch would not transfer its arc to the workpiece. The power supplies and torches were swapped to ensure that neither were at fault. However, both systems functioned as previously described. Neither torch worked as disclosed in the aforementioned patents.

**[0018]** Furthermore, the Multiplaz is not a continuous use plasma torch.

**[0019]** Hypertherm's U.S. Pat. No. 4,791,268, titled "Arc Plasma Torch and method using contact starting" and issued on Dec. 13, 1988 teaches and discloses "an arc plasma torch includes a moveable cathode and a fixed anode which are automatically separated by the buildup of gas pressure within the torch after a current flow is established between the cathode and the anode. The gas pressure draws a nontransferred pilot arc to produce a plasma jet. The torch is thus contact started, not through contact with an external workpiece, but through internal contact of the cathode and anode. Once the pilot arc is drawn, the torch may be used in the nontransferred mode, or the arc may be easily transferred to a workpiece. In a preferred embodiment, the cathode has a piston part which slidingly moves within a cylinder when sufficient gas pres-

sure is supplied. In another embodiment, the torch is a hand-held unit and permits control of current and gas flow with a single control."

**[0020]** There is absolutely no disclosure of coupling this torch to a solid oxide glow discharge cell.

**[0021]** Weldtronic Limited's, "Plasma cutting and welding torches with improved nozzle electrode cooling" U.S. Pat. No. 4,463,245 issued on Jul. 31, 1984 discloses "A plasma torch (40) comprises a handle (41) having an upper end (41B) which houses the components forming a torch body (43). Body (33) incorporates a rod electrode (10) having an end which cooperates with an annular tip electrode (13) to form a spark gap. An ionizable fuel gas is fed to the spark gap via tube (44) within the handle (41), the gas from tube (44) flowing axially along rod electrode (10) and being diverted radially through apertures (16) so as to impinge upon and act as a coolant for a thin-walled portion (14) of the annular tip electrode (13). With this arrangement the heat generated by the electrical arc in the inter-electrode gap is substantially confined to the annular tip portion (13A) of electrode (13) which is both consumable and replaceable in that portion (13A) is secured by screw threads to the adjoining portion (13B) of electrode (13) and which is integral with the thin-walled portion (14)."

**[0022]** Once again there is absolutely no disclosure of coupling this torch to a solid oxide glow discharge cell.

**[0023]** The following is a list of prior art teachings with respect to starting a torch and modes of operation.

---

2784294	Welding torch	March, 1957	Gravert 219/75
2898441	Arc torch push starting	August, 1959	Reed et al. 219/75
2923809	Arc cutting of metals	February, 1960	Clews et al. 219/75
3004189	Combination automatic-starting electrical plasma torch and gas shutoff valve	October, 1961	Giannini 219/75
3082314	Plasma arc torch	March, 1963	Arata et al. 219/75
3131288	Electric arc torch	April, 1964	Browning 219/121P
3242305	Pressure retract arc torch	March, 1966	Kane et al. 219/121PM
3534388	PLASMA JET CUTTING PROCESS	October, 1970	Ito et al. 219/121PM
3619549	ARC TORCH CUTTING PROCESS	November, 1971	Hogan et al. 219/121P
3641308	PLASMA ARC TORCH HAVING LIQUID LAMINAR FLOW JET FOR ARC CONSTRICTION	February, 1972	Couch, Jr. et al. 219/75
3787247		January, 1974	Couch, Jr. 148/9
3833787	PLASMA JET CUTTING TORCH HAVING REDUCED NOISE GENERATING CHARACTERISTICS	September, 1974	Couch, Jr. 219/75
4203022	Method and apparatus for positioning a plasma arc cutting torch	May, 1980	Couch, Jr. et al. 219/121P
4463245	Plasma cutting and welding torches with improved nozzle electrode cooling	July, 1984	McNeil 219/121PM
4567346	Arc-striking method for a welding or cutting torch and a torch adapted to carry out said method	January, 1986	Marhic 219/121PR

---

**[0024]** High temperature steam electrolysis and glow discharge are two technologies that are currently being viewed as the future for the hydrogen economy. Likewise, coal gasification is being viewed as the technology of choice for reducing carbon, sulfur dioxide and mercury emissions from coal burning power plants. Renewables such as wind turbines, hydroelectric and biomass are being exploited in order to reduce global warming. Water is one of our most valuable resources. Copious amounts of water are used in industrial processes with the end result of producing wastewater.

**[0025]** Water treatment and wastewater treatment go hand in hand with the production of energy.

**[0026]** Therefore, a need exists for an all electric system that can regenerate, concentrate or convert waste materials such as black liquor, spent caustic, phosphogypsum tailings water, wastewater biosolids and refinery tank bottoms to valuable feedstocks or products such as regenerated caustic soda, regenerated sulfuric acid, concentrated phosphoric acid, syngas or hydrogen and steam. Although world-class size refineries, petrochem facilities, chemical plants, upstream heavy oil, oilsands, gas facilities and pulp and paper mills would greatly benefit from such a system, there exists a dire need for a distributed all electric mini-refinery that can treat water while also cogenerate heat and fuel.

#### SUMMARY OF THE INVENTION

**[0027]** The present invention provides a glow discharge cell comprising an electrically conductive cylindrical vessel having a first end and a second end, and at least one inlet and one outlet; a hollow electrode aligned with a longitudinal axis of the cylindrical vessel and extending at least from the first end to the second end of the cylindrical vessel, wherein the hollow electrode has an inlet and an outlet; a first insulator that seals the first end of the cylindrical vessel around the hollow electrode and maintains a substantially equidistant gap between the cylindrical vessel and the hollow electrode; a second insulator that seals the second end of the cylindrical vessel around the hollow electrode and maintains the substantially equidistant gap between the cylindrical vessel and the hollow electrode; a non-conductive granular material disposed within the gap, wherein the non-conductive granular material (a) allows an electrically conductive fluid to flow between the cylindrical vessel and the hollow electrode, and (b) prevents electrical arcing between the cylindrical vessel and the hollow electrode during a electric glow discharge; and wherein the electric glow discharge is created whenever: (a) the glow discharge cell is connected to an electrical power source such that the cylindrical vessel is an anode and the hollow electrode is a cathode, and (b) the electrically conductive fluid is introduced into the gap.

**[0028]** The present invention also provides a glow discharge cell comprising: an electrically conductive cylindrical vessel having a first end and a closed second end, an inlet proximate to the first end, and an outlet centered in the closed second end; a hollow electrode aligned with a longitudinal axis of the cylindrical vessel and extending at least from the first end into the cylindrical vessel, wherein the hollow electrode has an inlet and an outlet; a first insulator that seals the first end of the cylindrical vessel around the hollow electrode and maintains a substantially equidistant gap between the cylindrical vessel and the hollow electrode; a non-conductive granular material disposed within the gap, wherein the non-conductive granular material (a) allows an electrically conductive fluid to flow between the cylindrical vessel and the

hollow electrode, and (b) prevents electrical arcing between the cylindrical vessel and the hollow electrode during a electric glow discharge; and wherein the electric glow discharge is created whenever: (a) the glow discharge cell is connected to an electrical power source such that the cylindrical vessel is an anode and the hollow electrode is a cathode, and (b) the electrically conductive fluid is introduced into the gap.

**[0029]** The present invention is described in detail below with reference to the accompanying drawings.

#### BRIEF DESCRIPTION OF THE DRAWINGS

**[0030]** The above and further advantages of the invention may be better understood by referring to the following description in conjunction with the accompanying drawings, in which:

**[0031]** FIG. 1 is a diagram of a plasma arc torch in accordance with one embodiment of the present invention;

**[0032]** FIG. 2 is a cross-sectional view comparing and contrasting a solid oxide cell to a liquid electrolyte cell in accordance with one embodiment of the present invention;

**[0033]** FIG. 3 is a graph showing an operating curve a glow discharge cell in accordance with one embodiment of the present invention.

**[0034]** FIG. 4 is a cross-sectional view of a glow discharge cell in accordance with one embodiment of the present invention;

**[0035]** FIG. 5 is a cross-sectional view of a glow discharge cell in accordance with another embodiment of the present invention;

**[0036]** FIG. 6 is a cross-sectional view of a Solid Oxide Plasma Arc Torch System in accordance with another embodiment of the present invention;

**[0037]** FIG. 7 is a cross-sectional view of a Solid Oxide Plasma Arc Torch System in accordance with another embodiment of the present invention;

**[0038]** FIG. 8 is a cross-sectional view of a Solid Oxide Transferred Arc Plasma Torch in accordance with another embodiment of the present invention;

**[0039]** FIG. 9 is a cross-sectional view of a Solid Oxide Non-Transferred Arc Plasma Torch in accordance with another embodiment of the present invention; and

**[0040]** FIG. 10 is a table showing the results of the tailings pond water and solids analysis treated with one embodiment of the present invention.

#### DETAILED DESCRIPTION OF THE INVENTION

**[0041]** While the making and using of various embodiments of the present invention are discussed in detail below, it should be appreciated that the present invention provides many applicable inventive concepts that can be embodied in a wide variety of specific contexts. The specific embodiments discussed herein are merely illustrative of specific ways to make and use the invention and do not delimit the scope of the invention.

**[0042]** Now referring to FIG. 1, a plasma arc torch **100** in accordance with one embodiment of the present invention is shown. The plasma arc torch **100** is a modified version of the ARCWHIRL® device disclosed in U.S. Pat. No. 7,422,695 (which is hereby incorporated by reference in its entirety) that produces unexpected results. More specifically, by attaching a discharge volute **102** to the bottom of the vessel **104**, closing off the vortex finder, replacing the bottom electrode with a hollow electrode nozzle **106**, an electrical arc can be main-

tained while discharging plasma 108 through the hollow electrode nozzle 106 regardless of how much gas (e.g., air), fluid (e.g., water) or steam 110 is injected into plasma arc torch 100. In addition, when a valve (not shown) is connected to the discharge volute 102, the mass flow of plasma 108 discharged from the hollow electrode nozzle 106 can be controlled by throttling the valve (not shown) while adjusting the position of the first electrode 112 using the linear actuator 114.

[0043] As a result, plasma arc torch 100 includes a cylindrical vessel 104 having a first end 116 and a second end 118. A tangential inlet 120 is connected to or proximate to the first end 116 and a tangential outlet 102 (discharge volute) is connected to or proximate to the second end 118. An electrode housing 122 is connected to the first end 116 of the cylindrical vessel 104 such that a first electrode 112 is aligned with the longitudinal axis 124 of the cylindrical vessel 104, extends into the cylindrical vessel 104, and can be moved along the longitudinal axis 124. Moreover, a linear actuator 114 is connected to the first electrode 112 to adjust the position of the first electrode 112 within the cylindrical vessel 104 along the longitudinal axis of the cylindrical vessel 124 as indicated by arrows 126. The hollow electrode nozzle 106 is connected to the second end 118 of the cylindrical vessel 104 such that the center line of the hollow electrode nozzle 106 is aligned with the longitudinal axis 124 of the cylindrical vessel 104. The shape of the hollow portion 128 of the hollow electrode nozzle 106 can be cylindrical or conical. Moreover, the hollow electrode nozzle 106 can extend to the second end 118 of the cylindrical vessel 104 or extend into the cylindrical vessel 104 as shown. As shown in FIG. 1, the tangential inlet 120 is volute attached to the first end 116 of the cylindrical vessel 104, the tangential outlet 102 is a volute attached to the second end 118 of the cylindrical vessel 104, the electrode housing 122 is connected to the inlet volute 120, and the hollow electrode nozzle 106 (cylindrical configuration) is connected to the discharge volute 102. Note that the plasma arc torch 100 is not shown to scale.

[0044] A power supply 130 is electrically connected to the plasma arc torch 100 such that the first electrode 112 serves as the cathode and the hollow electrode nozzle 106 serves as the anode. The voltage, power and type of the power supply 130 is dependant upon the size, configuration and function of the plasma arc torch 100. A gas (e.g., air), fluid (e.g., water) or steam 110 is introduced into the tangential inlet 120 to form a vortex 132 within the cylindrical vessel 104 and exit through the tangential outlet 102 as discharge 134. The vortex 132 confines the plasma 108 within in the vessel 104 by the inertia (inertial confinement as opposed to magnetic confinement) caused by the angular momentum of the vortex, whirling, cyclonic or swirling flow of the gas (e.g., air), fluid (e.g., water) or steam 110 around the interior of the cylindrical vessel 104. During startup, the linear actuator 114 moves the first electrode 112 into contact with the hollow electrode nozzle 106 and then draws the first electrode 112 back to create an electrical arc which forms the plasma 108 that is discharged through the hollow electrode nozzle 106. During operation, the linear actuator 114 can adjust the position of the first electrode 112 to change the plasma 108 discharge or account for extended use of the first electrode 112.

[0045] Referring now to FIG. 2, a cross-sectional view comparing and contrasting a solid oxide cell 200 to a liquid electrolyte cell 250 in accordance with one embodiment of the present invention is shown. An experiment was conducted using the Liquid Electrolyte Cell 250. A carbon cathode 202

was connected a linear actuator 204 in order to raise and lower the cathode 202 into a carbon anode crucible 206. An ESAB ESP150 DC power supply rated at 150 amps and an open circuit voltage ("OCV") of 370 VDC was used for the test. The power supply was "tricked out" in order to operate at OCV.

[0046] In order to determine the sheath glow discharge length on the cathode 202 as well as measure amps and volts the power supply was turned on and then the linear actuator 204 was used to lower the cathode 202 into an electrolyte solution of water and baking soda. Although a steady glow discharge could be obtained the voltage and amps were too erratic to record. Likewise, the power supply constantly surged and pulsed due to erratic current flow. As soon as the cathode 202 was lowered too deep, the glow discharge ceased and the cell went into an electrolysis mode. In addition, since boiling would occur quite rapidly and the electrolyte would foam up and go over the sides of the carbon crucible 206, foundry sand was added reduce the foam in the crucible 206.

[0047] The 8" diameter anode crucible 206 was filled with sand and the electrolyte was added to the crucible. Power was turned on and the cathode 202 was lowered into the sand and electrolyte. Unexpectedly, a glow discharge was formed immediately, but this time it appeared to spread out laterally from the cathode 202. A large amount of steam was produced such that it could not be seen how far the glow discharge had extended through the sand.

[0048] Next, the sand was replaced with commonly available clear floral marbles. When the cathode 202 was lowered into the marbles and baking soda/water solution, the electrolyte began to slowly boil. As soon as the electrolyte began to boil a glow discharge spider web could be seen throughout the marbles as shown the Solid Oxide Cell 200. Although this was completely unexpected at a much lower voltage than what has been disclosed and published, what was completely unexpected is that the DC power supply did not surge, pulse or operate erratically in any way. A graph showing an operating curve for a glow discharge cell in accordance with the present invention is shown in FIG. 3 based on various tests. The data is completely different from what is currently published with respect to glow discharge graphs and curves developed from currently known electro-plasma, plasma electrolysis or glow discharge reactors. Glow discharge cells can evaporate or concentrate liquids while generating steam.

[0049] Now referring to FIG. 4, a cross-sectional view of a glow discharge cell 400 in accordance with one embodiment of the present invention is shown. The glow discharge cell 400 includes an electrically conductive cylindrical vessel 402 having a first end 404 and a second end 406, and at least one inlet 408 and one outlet 410. A hollow electrode 412 is aligned with a longitudinal axis of the cylindrical vessel 402 and extends at least from the first end 404 to the second end 406 of the cylindrical vessel 402. The hollow electrode 412 also has an inlet 414 and an outlet 416. A first insulator seals 418 the first end 404 of the cylindrical vessel 402 around the hollow electrode 412 and maintains a substantially equidistant gap 420 between the cylindrical vessel 402 and the hollow electrode 412. A second insulator 422 seals the second end 406 of the cylindrical vessel 402 around the hollow electrode 412 and maintains the substantially equidistant gap 420 between the cylindrical vessel 402 and the hollow electrode 412. A non-conductive granular material 424 is disposed within the gap 420, wherein the non-conductive granular material 424 (a) allows an electrically conductive fluid to flow

between the cylindrical vessel **402** and the hollow electrode **412**, and (b) prevents electrical arcing between the cylindrical vessel **402** and the hollow electrode **412** during a electric glow discharge. The electric glow discharge is created whenever: (a) the glow discharge cell **400** is connected to an electrical power source such that the cylindrical vessel **402** is an anode and the hollow electrode **412** is a cathode, and (b) the electrically conductive fluid is introduced into the gap **420**.

[0050] The vessel **402** can be made of stainless steel and the hollow electrode can be made of carbon. The non-conductive granular material **424** can be marbles, ceramic beads, molecular sieve media, sand, limestone, activated carbon, zeolite, zirconium, alumina, rock salt, nut shell or wood chips. The electrical power supply can operate in a range from 50 to 500 volts DC, or a range of 200 to 400 volts DC. The cathode **412** can reach a temperature of at least 500° C., at least 1000° C., or at least 2000° C. during the electric glow discharge. The electrically conductive fluid comprises water, produced water, wastewater, tailings pond water, or other suitable fluid. The electrically conductive fluid can be created by adding an electrolyte, such as baking soda, Nahcolite, lime, sodium chloride, ammonium sulfate, sodium sulfate or carbonic acid, to a fluid.

[0051] Referring now to FIG. 5, a cross-sectional view of a glow discharge cell **500** in accordance with another embodiment of the present invention is shown. The glow discharge cell **500** includes an electrically conductive cylindrical vessel **402** having a first end **404** and a closed second end **502**, an inlet proximate **408** to the first end **404**, and an outlet **410** centered in the closed second end **502**. A hollow electrode **504** is aligned with a longitudinal axis of the cylindrical vessel and extends at least from the first end **404** into the cylindrical vessel **402**. The hollow electrode **504** has an inlet **414** and an outlet **416**. A first insulator **418** seals the first end **404** of the cylindrical vessel **402** around the hollow electrode **504** and maintains a substantially equidistant gap **420** between the cylindrical vessel **402** and the hollow electrode **504**. A non-conductive granular material **424** is disposed within the gap **420**, wherein the non-conductive granular material **424** (a) allows an electrically conductive fluid to flow between the cylindrical vessel **402** and the hollow electrode **504**, and (b) prevents electrical arcing between the cylindrical vessel **402** and the hollow electrode **504** during a electric glow discharge. The electric glow discharge is created whenever: (a) the glow discharge cell **500** is connected to an electrical power source such that the cylindrical vessel **402** is an anode and the hollow electrode **504** is a cathode, and (b) the electrically conductive fluid is introduced into the gap **420**.

[0052] The following examples will demonstrate the capabilities, usefulness and completely unobvious and unexpected results.

#### Example 1

##### Black Liquor

[0053] Now referring to FIG. 6, a cross-sectional view of a Solid Oxide Plasma Arc Torch System **600** in accordance with another embodiment of the present invention is shown. A plasma arc torch **100** is connected to the cell **500** via an eductor **602**. Once again the cell **500** was filled with a baking soda and water solution. A pump was connected to the plasma arc torch **100** via a 3-way valve **604** and the eductor **602**. The eductor **20** pulled a vacuum on the cell **10**. The plasma exiting from the plasma arc torch **100** dramatically increased in size.

Hence, a non-condensable gas was produced within the cell **500**. The color of the arc within the plasma arc torch **100** when viewed through the sightglass changed colors due to the gases produced from the HiTemper™ cell **500**. Next, the 3-way valve **604** was adjusted to allow air and water to flow into the plasma arc torch. The additional mass flow increased the plasma exiting from the plasma arc torch. Several pieces of stainless steel round bar were placed at the tip of the plasma and melted to demonstrate the systems capabilities. Likewise, wood was carbonized by placing it within the plasma stream. The water and gases exiting from the plasma arc torch **100** via volute flowed into a hydrocyclone **608** via a valve **606**. This allowed for rapid mixing and scrubbing of gases with the water in order to reduce the discharge of any hazardous contaminants.

[0054] A sample of black liquor with 16% solids obtained from a pulp and paper mill was charged to the glow discharge cell **500** in a sufficient volume to cover the floral marbles **424**. In contrast to other glow discharge or electro plasma systems the solid oxide glow discharge cell does not require preheating of the electrolyte. The ESAB ESP **150** power supply was turned on and the volts and amps were recorded by hand. Referring briefly to FIG. 3, as soon as the power was turned on to the cell **500**, the amp meter pegged out at **150**. Hence, the name of the ESAB power supply—ESP **150**. It is rated at 150 amps. The voltage was steady between 90 and 100 VDC. As soon as boiling occurred the voltage steadily climbed to OCV (370 VDC) while the amps dropped to 75.

[0055] The glow discharge cell **500** was operated until the amps fell almost to zero. Even at very low amps of less than 10 the voltage appeared to be locked on at 370 VDC. The cell **500** was allowed to cool and then opened to examine the marbles. It was surprising that there was no visible liquid left in the cell **500** but all of the marbles **424** were coated or coked with a black residue. The marbles **424** with the black residue were shipped off for analysis. The residue was in the bottom of the container and had come off of the marbles during shipping. The analysis is listed in the table below, which demonstrates a novel method for concentrating black liquor and coking organics. With a starting solids concentration of 16%, the solids were concentrated to 94.26% with only one evaporation step. Note that the sulfur (“S”) stayed in the residue and did not exit the cell **500**.

TABLE

Black Liquor Results		
Total Solids %	94.26	
Ash %/ODS	83.64	
DCM extractives %/ODS	will be available soon	
ICP metal scan: results are reported on ODS basis		
Metal Scan	Unit	F80015
Aluminum, Al	mg/kg	3590*
Arsenic, As	mg/kg	<50
Barium, Ba	mg/kg	2240*
Boron, B	mg/kg	60
Cadmium, Cd	mg/kg	2
Calcium, Ca	mg/kg	29100*
Chromium, Cr	mg/kg	31
Cobalt, Co	mg/kg	<5
Copper, Cu	mg/kg	19
Iron, Fe	mg/kg	686*
Lead, Pb	mg/kg	<20
Lithium, Li	mg/kg	10
Magnesium, Mg	mg/kg	1710*



TABLE-continued

Black Liquor Results		
Manganese, Mn	mg/kg	46.2
Molybdenum, Mo	mg/kg	40
Nickel, Ni	mg/kg	<100
Phosphorus, P	mg/kg	35
Potassium, K	mg/kg	7890

This method can be used for concentrating black liquor from pulp, paper and fiber mills for subsequent recaustizing.

[0056] As can be seen in FIG. 3, if all of the liquid evaporates from the cell 500 and it is operated only with a solid electrolyte, electrical arc over from the cathode to anode may occur. This has been tested in which case a hole was blown through the stainless steel vessel 402. Electrical arc over can easily be prevented by (1) monitoring the liquid level in the cell and do not allow it to run dry, and (2) monitoring the amps (Low amps=Low liquid level). If electrical arc over is desirable or the cell must be designed to take an arc over, then the vessel 402 should be constructed of carbon.

#### Example 2

##### Arcwhirl® Plasma Torch Attached to Solid Oxide Cell

[0057] Referring now to FIG. 7, a cross-sectional view of a Solid Oxide Plasma Arc Torch System 700 in accordance with another embodiment of the present invention is shown. A plasma arc torch 100 is connected to the cell 500 via an eductor 602. Once again the cell 500 was filled with a baking soda and water solution. A pump 22 was connected to the plasma arc torch 100 via a 3-way valve 604 and the eductor 602. An air compressor 21 was used to introduce air into the 3-way valve 604 along with water from the pump 22. The pump was turned on and water flowed into a first volute 31 of the plasma arc torch 100 and through a full view site glass 33 and exited the torch 30 via a second volute 34. The plasma arc torch 100 was started by pushing a carbon cathode rod (-NEG) 32 to touch and dead short to a positive carbon anode (+POS) 35. A very small plasma G exited out of the anode 35. Next, the High Temperature Plasma Electrolysis Reactor (Cell) 500 was started in order to produce a plasma gas. Once again at the onset of boiling voltage climbed to OCV (370 vdc) and a gas began flowing to the plasma arc torch 30. The eductor 20 pulled a vacuum on the cell 10. The plasma exiting from the plasma arc torch 100 dramatically increased in size. Hence, a non-condensable gas was produced within the cell 10. The color of the arc within the plasma arc torch 100 when viewed through the sightglass 33 changed colors due to the gases produced from the HiTemper™ cell 500. Next, the 3-way valve 604 was adjusted to allow air and water to flow into the plasma arc torch 100. The additional mass flow increased the plasma G exiting from the plasma arc torch 100. Several pieces of stainless steel round bar were placed at the tip of the plasma and melted to demonstrate the systems capabilities. Likewise, wood was carbonized by placing it within the plasma stream. The water and gases exiting from the plasma arc torch 100 via volute 34 flowed into a hydrocyclone 608. This allowed for rapid mixing and scrubbing of gases with the water in order to reduce the discharge of any hazardous contaminants.

[0058] Next, the system was shut down and a 2nd cyclone separator 52 was attached to the plasma arc torch 100 as shown in FIG. 5. Once again the Solid Oxide Plasma Arc Torch System was turned on and a plasma could be seen circulating within the cyclone separator 52. Within the eye or vortex of the whirling plasma was a central core devoid of any visible plasma.

[0059] The cyclone separator was removed to conduct another test. To determine the capabilities of the Solid Oxide Plasma Arc Torch System as shown in FIG. 6, the pump 22 was turned off and the system was operated only on air provided by compressor 21 and gases produced from the solid oxide cell 500. Next, 3-way valve 606 was slowly closed in order to force all of the gases through the arc to form a large plasma exiting from the hollow carbon anode 35.

[0060] Next, the 3-way valve 604 was slowly closed to shut the flow of air to the plasma arc torch 100. What happened was completely unexpected. The intensity of the light from the sightglass 33 increased dramatically and a brilliant plasma was discharged from the plasma arc torch 100. When viewed with a welding shield the arc was blown out of the plasma arc torch 100 and wrapped back around to the anode 35. Thus, the Solid Oxide Plasma Arc Torch System will produce a gas and a plasma suitable for welding, melting, cutting, spraying and chemical reactions such as pyrolysis, gasification and water gas shift reaction.

#### Example 3

##### Phosphogypsum Pond Water

[0061] The phosphate industry has truly left a legacy in Florida, Louisiana and Texas that will take years to cleanup—gypsum stacks and pond water. On top of every stack is a pond. Pond water is recirculated from the pond back down to the plant and slurried with gypsum to go up the stack and allow the gypsum to settle out in the pond. This cycle continues and the gypsum stack increases in height. The gypsum is produced as a byproduct from the ore extraction process.

[0062] There are 2 major environmental issues with every gyp stack. First, the pond water has a very low pH. It cannot be discharged without neutralization. Second, the phosphogypsum contains a slight amount of radon. Thus, it cannot be used or recycled to other industries. The excess water in combination with ammonia contamination produced during the production of P2O5 fertilizers such as diammonium phosphate (“DAP”) and monammonium phosphate (“MAP”) must be treated prior to discharge. The excess pond water contains about 2% phosphate a valuable commodity.

[0063] A sample of pond water was obtained from a Houston phosphate fertilizer company. The pond water was charged to the solid oxide cell 500. The Solid Oxide Plasma Arc Torch System was configured as shown in FIG. 6. The 3-way valve 606 was adjusted to flow only air into the plasma arc torch 100 while pulling a vacuum on cell 500 via eductor 602. The hollow anode 35 was blocked in order to maximize the flow of gases to hydrocyclone 608 that had a closed bottom with a small collection vessel. The hydrocyclone 608 was immersed in a tank in order to cool and recover condensable gases.

[0064] The results are disclosed in FIG. 10—Tailings Pond Water Results. The goal of the test was to demonstrate that the Solid Oxide Glow Discharge Cell could concentrate up the tailings pond water. Turning now to cycles of concentration, the % P2O5 was concentrated up by a factor of 4 for a final

concentration of 8.72% in the bottom of the HiTemper™ cell **500**. The beginning sample as shown in the picture is a colorless, slightly cloudy liquid. The bottoms or concentrate recovered from the HiTemper cell **500** was a dark green liquid with sediment. The sediment was filtered and are reported as SOLIDS (Retained on Whatmann #40 filter paper). The % SO<sub>4</sub> recovered as a solid increased from 3.35% to 13.6% for a cycles of concentration of 4. However, the % Na recovered as a solid increased from 0.44% to 13.67% for a cycles of concentration of 31.

**[0065]** The solid oxide or solid electrolyte **14** used in the cell **500** were floral marbles (Sodium Oxide). Floral marbles are made of sodium glass. Not being bound by theory it is believed that the marbles were partially dissolved by the phosphoric acid in combination with the high temperature glow discharge. Chromate and Molydemun cycled up and remained in solution due to forming a sacrificial anode from the stainless steel vessel **11**. Note: Due to the short height of the cell carryover occurred due to pulling a vacuum on the cell **11** with eductor **20**. In the first run (row **1** HiTemper) of FIG. **10** very little fluorine went overhead. That had been a concern from the beginning that fluorine would go over head. Likewise about 38% of the ammonia went overhead. It was believed that all of the ammonia would flash and go overhead.

**[0066]** A method has been disclosed for concentrating P<sub>2</sub>O<sub>5</sub> from tailings pond for subsequent recovery as a valuable commodity acid and fertilizer.

**[0067]** Now, returning back to the black liquor sample, not being bound by theory it is believed that the black liquor can be recausticized by simply using CaO or limestone as the solid oxide electrolyte **14** within the cell **10**. Those who are skilled in the art of producing pulp and paper will truly understand the benefits and cost savings of not having to run a lime kiln. However, if the concentrated black liquor must be gasified or thermally oxidized to remove all carbon species, the marbles can be treated with the plasma arc torch **100**. Referring back to FIG. **6**, the marbles coated with the concentrated black liquor or the concentrated black liquor only is injected between the plasma arc torch **100** and the cyclone separator **610**. This will convert the black liquor into a green liquor or maybe a white liquor. The marbles may be flowed into the plasma arc torch nozzle **35** and quenched in the whirling lime water and discharged via volute **34** into hydrocyclone **608** for separation and recovery of both white liquor and the marbles. The lime will react with the NaO to form caustic and an insoluble calcium carbonate precipitate.

#### Example 4

##### Evaporation, Vapor Compression and Steam Generation for EOR and Industrial Steam Users

**[0068]** Turning to FIG. **200**, several oilfield wastewaters were evaporated in the cell **250**. In order to enhance evaporation the suction side of a vapor compressor (not shown) can be connected to outlet. The discharge of the vapor compressor would be connected to **12-A**. Not being bound by theory, it is believed that alloys such as Kanthal® manufactured by the Kanthal® corporation may survive the intense effects of the cell as a tubular cathode **12**, thus allowing for a novel steam generator with a superheater by flowing the discharge of the vapor compressor through the tubular cathode **12**. Such an apparatus, method and process would be widely used throughout the upstream oil and gas industry in order to treat oilfield produced water and frac flowback.

**[0069]** Several different stainless steel tubulars were tested within the cell **500** as the cathode **12**. In comparison to the sheath glow discharge the tubulars did not melt. In fact, when the tubulars were pulled out, a marking was noticed at every point a marble was in contact with the tube.

**[0070]** This gives rise to a completely new method for using glow discharge to treat metals.

#### Example 5

##### Treating Tubes, Bars, Rods, Pipe or Wire

**[0071]** There are many different companies applying glow discharge to treat metal. However, many have companies have failed miserably due to arcing over and melting the material to be coated, treated or descaled. The problem with not being able to control voltage leads to spikes. By simply adding sand or any solid oxide to the cell and feeding the tube cathode **12** through the cell **500** as configured in FIG. **2**, the tube, rod, pipe, bars or wire can be treated at a very high feedrate.

#### Example 6

##### Solid Oxide Plasma Arc Torch

**[0072]** There truly exists a need for a very simple plasma torch that can be operated with dirty or highly polluted water such as sewage flushed directly from a toilet which may contain toilet paper, feminine napkins, fecal matter, pathogens, urine and pharmaceuticals. A plasma torch system that could operate on the aforementioned waters could potentially dramatically affect the wastewater infrastructure and future costs of maintaining collection systems, lift stations and wastewater treatment facilities.

**[0073]** By converting the contaminated wastewater to a gas and using the gas as a plasma gas could also alleviate several other growing concerns—municipal solid waste going to landfills, grass clippings and tree trimmings, medical waste, chemical waste, refinery tank bottoms, oilfield wastes such as drill cuttings and typical everyday household garbage. A simple torch system which could handle both solid waste and liquids or that could heat a process fluid while gasifying

**[0074]** One industry in particular is the metals industry. The metals industry requires a tremendous amount of energy and exotic gases for heating, melting, welding, cutting and machining.

**[0075]** Turning now to FIGS. **8** and **9**, a truly novel plasma torch will be disclosed in accordance with the preferred embodiments of the present invention. First, the Solid Oxide Plasma Torch is constructed by coupling the plasma arc torch **100** to the cell **10**. The plasma arc torch volute **31** and electrode **32** are detached from the eductor **20** and sightglass **33**. The plasma arc torch volute **31** and electrode assembly **32** are attached to the cell **500** vessel **11**. The sightglass **33** is replaced with a concentric type reducer **33**. It is understood that the electrode **32** is electrically isolated from the volute **31** and vessel **11**. The electrode is connected to a linear actuator (not shown) in order to strike the arc.

**[0076]** Continuous Operation of the Solid Oxide Transferred Arc Plasma Torch as shown in FIG. **8** will now be disclosed for cutting or melting an electrically conductive workpiece. A fluid is flowed into the suction side of the pump and into the cell **500**. The pump is stopped. A first power supply PS1 is turned on thus energizing the cell. As soon as the cell **500** goes into glow discharge and a gas is produced valve

**16** opens allowing the gas to enter into the volute **31**. The volute imparts a whirl flow to the gas. A switch **60** is positioned such that a second power supply PS2 is connected to the workpiece and the –negative side of PS2 is connected to the –negative of PS1 which is connected to the centered cathode **12** of the cell **10**. The entire torch is lowered so that an electrically conductive nozzle **13-C** touches and is grounded to the workpiece. PS2 is now energized and the torch is raised from the workpiece. An arc is formed between cathode and the workpiece.

**[0077]** Centering the Arc—If the arc must be centered for cutting purposes, then PS2's –negative lead would be attached to the lead of switch **60** that goes to the cathode **32**. Although a series of switches are not shown for this operation, it will be understood that in lieu of manually switching the negative lead from PS2 an electrical switch similar to **60** could be used for automation purposes. The +positive lead would simply go to the workpiece as shown. A smaller electrode **32** would be used such that it could slide into and through the hollow cathode **12** in order to touch the workpiece and strike an arc. The electrically conductive nozzle **13-C** would be replaced with a non-conducting shield nozzle. This setup allows for precision cutting using just wastewater and no other gases.

**[0078]** Turning to FIG. 9, the Solid Oxide Non-Transferred Arc Plasma Torch is used primarily for melting, gasifying and heating materials while using a contaminated fluid as the plasma gas. Switch **60** is adjusted such that PS2+lead feeds electrode **32**. Once again electrode **32** is now operated as the anode. It must be electrically isolated from vessel **11**. When gas begins to flow by opening valve **16** the volute imparts a spin or whirl flow to the gas. The anode **32** is lowered to touch the centered cathode. An arc is formed between the cathode and anode. The anode may be hollow and a wire may be fed through the anode for plasma spraying, welding or initiating the arc.

**[0079]** The entire torch is regeneratively cooled with its own gases thus enhancing efficiency. Likewise, a waste fluid is used as the plasma gas which reduces disposal and treatment costs. Finally, the plasma may be used for gasifying coal, biomass or producing copious amounts of syngas by steam reforming natural gas with the hydrogen and steam plasma.

**[0080]** Both FIGS. 8 and 9 have clearly demonstrated a novel Solid Oxide Plasma Arc Torch that couples the efficiencies of high temperature electrolysis with the capabilities of both transferred and non-transferred arc plasma torches.

**[0081]** The foregoing description of the apparatus and methods of the invention in preferred and alternative embodiments and variations, and the foregoing examples of processes for which the invention may be beneficially used, are intended to be illustrative and not for purpose of limitation. The invention is susceptible to still further variations and alternative embodiments within the full scope of the invention, recited in the following claims.

What is claimed is:

1. A glow discharge cell comprising:

an electrically conductive cylindrical vessel having a first end and a second end, and at least one inlet and one outlet;

a hollow electrode aligned with a longitudinal axis of the cylindrical vessel and extending at least from the first end to the second end of the cylindrical vessel, wherein the hollow electrode has an inlet and an outlet;

a first insulator that seals the first end of the cylindrical vessel around the hollow electrode and maintains a substantially equidistant gap between the cylindrical vessel and the hollow electrode;

a second insulator that seals the second end of the cylindrical vessel around the hollow electrode and maintains the substantially equidistant gap between the cylindrical vessel and the hollow electrode;

a non-conductive granular material disposed within the gap, wherein the non-conductive granular material (a) allows an electrically conductive fluid to flow between the cylindrical vessel and the hollow electrode, and (b) prevents electrical arcing between the cylindrical vessel and the hollow electrode during a electric glow discharge; and

wherein the electric glow discharge is created whenever:

(a) the glow discharge cell is connected to an electrical power source such that the cylindrical vessel is an anode and the hollow electrode is a cathode, and (b) the electrically conductive fluid is introduced into the gap.

2. The glow discharge cell as recited in claim 1, wherein the non-conductive granular material comprises marbles, ceramic beads, molecular sieve media, sand, limestone, activated carbon, zeolite, zirconium, alumina, rock salt, nut shell or wood chips.

3. The glow discharge cell as recited in claim 1, wherein the electrical power supply operates in a range from 50 to 500 volts DC.

4. The glow discharge cell as recited in claim 1, wherein the electrical power supply operates in a range of 200 to 400 volts DC.

5. The glow discharge cell as recited in claim 1, wherein the cathode reaches a temperature of at least 500° C. during the electric glow discharge.

6. The glow discharge cell as recited in claim 1, wherein the cathode reaches a temperature of at least 1000° C. during the electric glow discharge.

7. The glow discharge cell as recited in claim 1, wherein the cathode reaches a temperature of at least 2000° C. during the electric glow discharge.

8. The apparatus as recited in claim 1, wherein the electrically conductive fluid comprises water, produced water, wastewater or tailings pond water.

9. The apparatus as recited in claim 8, wherein: the electrically conductive fluid is created by adding an electrolyte to a fluid; and

the electrolyte comprises baking soda, Nahcolite, lime, sodium chloride, ammonium sulfate, sodium sulfate or carbonic acid.

10. A glow discharge cell comprising:

an electrically conductive cylindrical vessel having a first end and a closed second end, an inlet proximate to the first end, and an outlet centered in the closed second end;

a hollow electrode aligned with a longitudinal axis of the cylindrical vessel and extending at least from the first end into the cylindrical vessel, wherein the hollow electrode has an inlet and an outlet;

a first insulator that seals the first end of the cylindrical vessel around the hollow electrode and maintains a substantially equidistant gap between the cylindrical vessel and the hollow electrode;

a non-conductive granular material disposed within the gap, wherein the non-conductive granular material (a) allows an electrically conductive fluid to flow between the cylindrical vessel and the hollow electrode, and (b)

prevents electrical arcing between the cylindrical vessel and the hollow electrode during a electric glow discharge; and wherein the electric glow discharge is created whenever:  
(a) the glow discharge cell is connected to an electrical

power source such that the cylindrical vessel is an anode and the hollow electrode is a cathode, and (b) the electrically conductive fluid is introduced into the gap.

\* \* \* \* \*